



Top-Load Washer

Power supply: 120V-
Frequency: 60Hz
Capacity: 4.7cu.ft.

Warning:
Before using this product,
please read this manual carefully
and keep it for future reference.
The design and specifications
are subject to change without
prior notice for product
improvement. Consult with
your dealer or manufacturer for
details.

version A

USER MANUAL & INSTALLATION INSTRUCTIONS

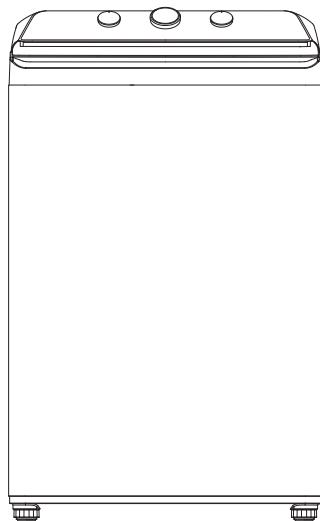

**Free 3 months
extension*** of the
original limited warranty
period! Simply text a
picture of your proof of
purchase to:

1-844-224-1614

*The warranty extension is for the
three months immediately following
the completion of the products
original warranty period.

MODEL NUMBERS
MLTW47A5BWW
MLTW47A5BGG
www.midea/ca

Dear user

THANK YOU for letting Midea help you “make yourself at home.” This manual is part of our commitment to your total satisfaction. Please read this manual carefully before use and keep it in a convenient place for future reference.

To help us serve you better, please consider registering your product using our convenient Midea app Msmartlife, by visiting **register@registrationplace.com** or by texting a picture of your proof of purchase to 1-844-224-1614.

By using the text option you will earn an additional 3 month warranty extension immediately following the completion of the following the completion of the product's original warranty.

SAFETY INSTRUCTIONS.....	4
FEATURES	11
Package contents.....	11
Main components.....	12
OPERATION REQUIREMENTS.....	13
Electrical requirements	13
Water requirements.....	14
Drainage requirements.....	14
INSTALLATION INSTRUCTIONS	15
Unpacking your washer	15
Choosing a location.....	16
Tools you will need	18
Connect the water hoses	19
Connect the drain hose.....	21
Level your washer	23
Power on.....	24
Run a test cycle.....	25
WASHER USE	26
Control panel.....	26
Washing a load of laundry	27
Selecting a detergent	27
Loading the fabric softener compartment.....	30

WASHER CARE	32
Cleaning and Maintenance	32
BEFORE YOU CALL FOR SERVICE	34
Troubleshooting tips	34
Error codes	37
WARRANTY	38
PRODUCT REGISTRATION	40

READ AND KEEP THESE INSTRUCTIONS FOR FUTURE REFERENCE

This manual contains important information on the installation, use, and care of your appliance. Please read this manual carefully before installation and operation of this machine to prevent injury and property damage.

Warnings and Important Safety Instructions in this manual DO NOT cover all possible conditions and situations that may occur. It is your responsibility to use common sense, caution and care when installing, maintaining and operating your washer.



**CAUTION
RISK OF ELECTRIC SHOCK
DO NOT OPEN**



SAFETY INSTRUCTIONS

YOUR SAFETY AND THE SAFETY OF OTHERS ARE VERY IMPORTANT

To prevent injury to the user or other people and property damage, the instructions shown here must be followed. Incorrect operation due to ignoring of instructions may cause harm or damage, including death.

The level of risk is shown by the following indications.



This indicates that hazards or unsafe practices may cause serious personal injury or death. To reduce the risk of fire, explosion, electric shock or personal injury when using your washing machine, you SHOULD follow these basic safety precautions.



This indicates that hazards or unsafe practices may cause minor personal injury or property damage.



This symbol indicates that there are important operating and maintenance instructions in the literature accompanying your washing machine.

WARNING

State of California Proposition 65 Warnings.

The California Safe Drinking Water and Toxic Enforcement Act requires the Governor of California to publish a list of substances known to the State of California to cause cancer, birth defects or other reproductive harm and requires businesses to warn of potential exposure to such substances. This product contains a chemical known to the State of California to cause cancer, birth defects or other reproductive harm. This appliance can cause low-level exposure to some of the substances listed, including benzene, formaldehyde and carbon monoxide. Cancer and Reproductive Harm - www.P65Warnings.ca.gov.

WARNING

Do not store or use gasoline or other flammable vapors and liquids in the vicinity of this or any other appliance.

IMPORTANT SAFETY INSTRUCTIONS

Save These INSTRUCTIONS

WARNING

- Read all instructions before using the appliance.
- Use this appliance only for its intended purpose as described in this Owner's Manual.
- Before use, the washer must be properly installed as described in this manual.
- ALWAYS follow the fabric care instructions supplied by the garment manufacturer.
- Do not wash articles that have been previously cleaned in, washed in, soaked in, or spotted with gasoline, dry-cleaning solvents, other flammable or explosive substances as they give off vapors that could ignite or explode.
- Do not allow children to play on or in the appliance. Close supervision of children is necessary when the appliance is used near children.
- Before the appliance is removed from service or discarded, remove the lid of the washing compartment.
- Do not reach into the appliance if the tub is moving.
- Do not install or store this appliance where it will be exposed to the weather or freezing temperatures.
- Do not tamper with the controls.
- Do not repair or replace any part of the appliance or attempt any servicing unless it is specifically recommended in the user maintenance instructions or in published user repair instructions that you understand.
- Hydrogen gas is explosive. If the hot water system has not been used for two weeks or more, before using a washer, turn on all hot water faucets and let the water flow from each for several minutes. This will release any accumulated hydrogen gas. The gas is flammable, so do not smoke or use an open flame during this time.
- Keep the area underneath and around your appliance free of combustible materials (lint, paper, rags and so on), gasoline chemicals, and other flammable vapors and liquids.
- Do not place items exposed to cooking oil in your washer. Items contaminated with cooking oil may contribute to a chemical reaction that could cause a load to catch fire.
- This washer is not designed for maritime use or for mobile installations such as in RVs aircraft and other mobile platforms.
- Turn off the water faucets and unplug the washer if the machine is to be left for an extended period of time, such as during vacations.
- Packaging material can be dangerous for children. There is a risk of suffocation! Keep all packaging away from children.
- Always check the inside of the washer for foreign objects before loading laundry. Keep the lid closed when not in use.



WARNING

- Plug the power cord into an AC 120V/60Hz wall socket rated at 15 amps or higher. Use the socket for this washer only. Do not use an extension cord.
 - Sharing a wall socket with another appliance, using a power strip, or extending the power cord may result in electric shock or fire.
 - Do not use an electric transformer. It may result in electric shock or fire.
 - Make sure that the power voltage, frequency and current match the product's specifications. Failing to do so may result in electric shock or fire.
- Remove all foreign substances such as dust or water from the power plug terminals and contact points using a dry cloth on a regular basis.
 - Unplug the power plug and clean it with a dry cloth.
 - Failing to do so may result in electric shock or fire.
- Plug the power plug into the wall socket in the right direction so that the cord runs towards the floor.
 - If you plug the power plug into the socket in the opposite direction, the electric wires within the cable may be damaged and this may result in electric shock or fire.
- Plug the power plug into the wall socket firmly. Do not use a damaged power plug or loose wall socket, because this may result in electric shock fire.
- Do not pull or excessively bend the power cord. Do not twist or tie the power cord.
- Do not hook the power cord over a metal object. Place a heavy object on the power cord, insert power cord between objects, or push the power cord into the space behind the appliance, because this may result in electric shock or fire.
- Do not pull the power cord when unplugging the power plug.
 - Unplug the power plug by holding the plug.
 - Failing to do so may result in electric shock or fire.
- If the power plug or power cord is damaged, contact your nearest service center.
- Do not install on carpet. Install the washer on a level and solid floor that can support its weight. Failure to do so may result in abnormal vibration, noise or problems with the product.
- The washer is heavy. Two or more people may be needed to install and move the appliance. Failure to do so may result in bodily or other injuries.
- Store and install the washer where it will not be exposed to temperatures below freezing or exposed to outdoor weather conditions. Failure to do so may result in serious leak damage.
- Position the appliance so that the power plug is easily accessible. Failure to do so may result in electric shock or fire due to an electrical short circuit.
- Failure to follow all of the safety warnings in this guide may result in property damage or injury to persons.
- Do not add gasoline, dry-cleaning solvents, or other flammable or explosive substances to the wash water. These substances give off vapours that ignite or explode.



WARNING

Use and Maintenance warnings and Precaution

- If the appliance is flooded, cut the power immediately and contact your nearest service center.
- If the appliance emits a strange noise, a burning smell or smoke, unplug the power plug immediately and contact your nearest service center. Failure to do so may result in electric shock or fire.
- In the event of a gas leak (such as propane or LP gas) ventilate the area immediately. Do not turn any appliance or light on or off.
 - Do not use a ventilating fan.
 - A spark may result in an explosion or fire.
- Do not force the washer lid open while the washer is operating (hightemperature washing, drying or spinning).
 - Water flowing out of the washer may cause burns or cause the floor to be slippery. This may result in injury.
 - Forcing the lid open can damage the product or cause injury.
- Make sure to remove the packaging (sponge, styrofoam) attached to the bottom of the washer before using it.
- Do not insert your hand or a metal object under the washer. This may result in injury.
- Do not attempt to operate this appliance if it is damaged, malfunctioning, partially disassembled or has missing or broken parts, including a damaged cord or plug. This may result in electric shock, fire or death.
- Do not touch the power plug with wet hands. This may result in electric shock.
- Do not turn the appliance off by unplugging the power plug while the washer is in operation. Plugging the power plug into the wall socket again may cause a spark and result in electric shock or fire.
- Keep all packaging material well out of the reach of children, as packaging materials can be dangerous to children. If a child places a bag over his or her head, he or she may suffocate.
- Do not let children or infirm persons use this washer unsupervised. Failure to do so may result in electric shock, burns or injury.
- Do not attempt to repair, disassemble or modify the appliance yourself.
 - Do not use any fuse (such as copper, steel wire etc.) other than the standard fuse.
 - If you need to repair or reinstall the appliance, contact your nearest service center.
 - Failure to do so may result in electric shock, fire, problems with the product or injury.
- If any foreign substance such as water enters the appliance in any area other than the tub, unplug the power plug and contact your nearest service center. Failure to do so may result in electric shock or fire.
- If the water supply hose comes loose from the faucet and floods the appliance, unplug the power plug. Failure to do so may result in electric shock or fire.

- Do not mix chlorine bleach with ammonia or acids such as vinegar. Incorrect usage can produce poisonous gas, resulting in serious injury.
- Do not reach into the washer while parts are moving. Before loading, unloading or adding items, press the Start/Pause button and allow the tub to come to a complete stop before reaching inside. Failure to do so may result in electric shock injury or fire.
- Do not allow children to play on or in the washer. Close supervision of children is necessary when the washer is used near children. As children grow, teach them the proper, safe use of all appliances. Failure to do so may result in serious injury.
- Keep laundry products out of reach of children. Observe all warnings on product labels and follow them. Failure to do so may result in serious injury.
- Disconnect this appliance from the power supply before attempting any user maintenance. Pressing the Power button does not disconnect this appliance from the power supply. Failure to do so may result in electric shock, injury or fire.
- Do not clean the appliance by spraying water directly onto it.
- Do not use benzene, thinner or alcohol to clean the appliance. This may result in discoloration, deformation, damage, electric shock or fire.
- Unplug the power plug when the appliance is not being used for long periods of time or during a thunder/lightning storm. Failure to do so may result in electric shock or fire.
- Keep hands and foreign objects clear of the lid and latch area when closing the lid. Failure to do so may result in personal injury.
- If the washer is contaminated by a foreign substance such as detergent, dirt, or food waste, unplug the power plug and clean the washer with a damp, soft cloth. Failure to do so may result in discoloration, deformation, damage or rust.
- The clear portion of the lid can be broken by a strong impact. Take care when using the washer. If the clear portion is cracked or broken, it may result in injury.
- After a water supply failure or when reconnecting the water supply hose, open the faucet slowly.
- Open the faucet slowly after a long period of non-use. The air pressure in the water supply hose or the water pipe may result in damage to a part or in water leakage.
- If a drain error occurs during an operation, check if there is a draining problem. If the washer is used when it is flooded because of a draining problem, it may result in electric shock or fire due to an electrical short circuit. Do not insert your hand or a metal object under the washer. This may result in injury.
- Insert laundry into the washer completely so that the laundry does not get caught in the lid. If laundry gets caught in the lid, it may result in damage to the laundry or the washer, or result in water leakage.
- Make sure that the faucet is turned off when the washer is not being used.
- Make sure that the water supply hose connectors are properly tightened. Failure to do so may result in property damage or injury.
- Open the faucet and check if the water supply hose connector is firmly tightened and that there is no water leaking before using the product. If the water supply hose connectors are loose, it may result in water leakage.

- Do not stand on top of the appliance or place objects (such as laundry, lighted candles, lighted cigarettes, dishes, chemicals, metal objects, etc.) on the appliance. This may result in electric shock, fire, problems with the product, or injury.
- Do not operate the appliance with wet hands. This may result in electric shock.
- Do not spray volatile material such as insecticide onto the surface of the appliance. As well as being harmful to humans, it may also result in electric shock, fire or problems with the product.
- Do not place an object that generates an electromagnetic field near the washer. This may result in injury due to a malfunction.
- Since the water drained during a high temperature wash or drying cycle is hot, do not touch the water. This may result in burns or injury.
- Do not wash, spin or dry water-proof seats, mats or clothing.
- Do not wash thick, hard mats even if the washer mark is on the care label. This may result in injury or damage to the washer, walls, floor or clothing due to abnormal vibrations.
- Do not operate the washer when the detergent dispenser is removed. This may result in electric shock or injury due to water leakage.
- Do not insert your hand into the detergent dispenser after opening it. This may result in injury because your hand may be caught.
- Do not place any non-laundry objects, such as shoes, food waste or animals into the washer. This can cause abnormal vibrations that can damage the washer, and in the case of pets, cause severe injury or death.
- Do not press the buttons using sharp objects such as pins, knives, or fingernails. This may result in electric shock or injury.
- Do not wash laundry contaminated by oils, creams or lotions usually found in skin-care shops or massage clinics. This may result in the rubber seal becoming deformed and water leakage.
- Make sure that the water inlet pipe is connected and the tap is opened before washing clothes.
- Do not leave metal objects (safety pins, hair pins, and so on) or bleach in the tub for long periods of time. This may cause the tub to rust.
 - If rust appears on the surface of the tub, apply a neutral cleansing agent to the surface and use a sponge to clean it. Never use a metal brush.
- Do not use hot water from water cooling/heating devices. This may result in problems with the washer.
- Do not use natural hand-washing soap in the washer. If it hardens and accumulates inside the washer, it may cause problems with the product, discoloration, rust or bad odors.
- If using a washing net with this machine (not provided), do not wash laundry items such as bedding in the washing net. Doing so may result in injury due to abnormal vibrations. Place only smaller items such as lace socks and lingerie in the washing net.
- Do not use hardened powdered detergent. If it accumulates inside the washer, it may result in water leakage.
- Do not wash throw rugs or doormats. Doing so may cause sand to accumulate inside the washer, resulting in mechanical problems.

WARNING

Grounding/Earthing

- This appliance must be properly grounded.
- Do not ground the appliance to a gas pipe, plastic water pipe or telephone line.
 - Improper grounding may result in electric shock, fire, explosion or problems with the product.
 - Never plug the power cord into a socket that is not grounded correctly. Make sure that the socket you use is grounded in correctly. Make sure that the socket you use is grounded in accordance with local and national codes.

WARNING

Grounding/Earthing

- Do not install this appliance near a heater or inflammable material.
- Do not install this appliance in a humid, oily or dusty location, or in a location exposed to direct sunlight or water (rain drops).
- Do not install this appliance in a location where gas may leak. Failure to do so may result in electric shock or fire.
- If the washer is moved to a new location, have it checked and reinstalled by a qualified service technician. Failure to follow this warning may result in electric shock or fire.
- Do not pull power cord or drain outlet hose to move appliance to desired location place.

FEATURES

Package Contents

Make sure that the following items came with your washer

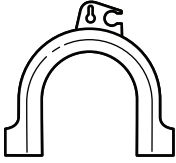

Drain Hose Guide (x1)



Manual



Tie (x1)



Filter (x2)

NOTE:

- Use the filters to replace the rubber washers in the water hoses (faucet sides).

Main Components

Safety
Instructions

Features

Operation
Requirements

Installation
Instructions

Washer Use

Washer Care

Troubleshooting

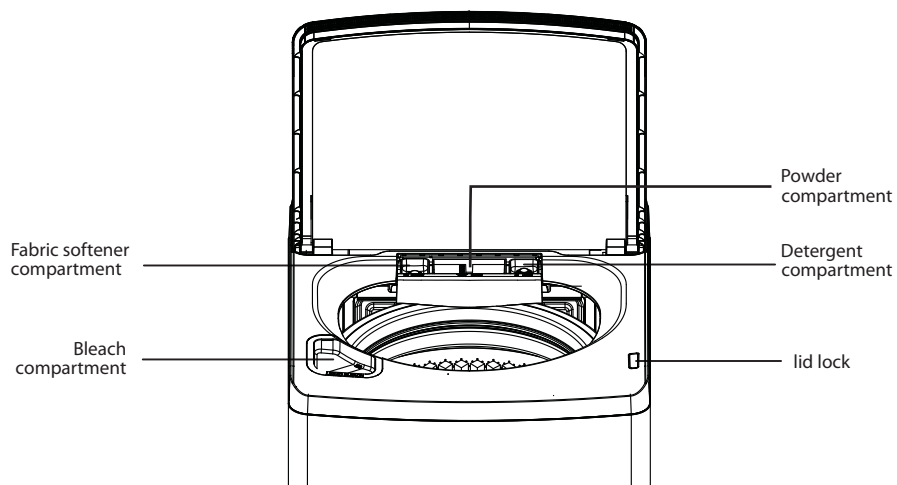
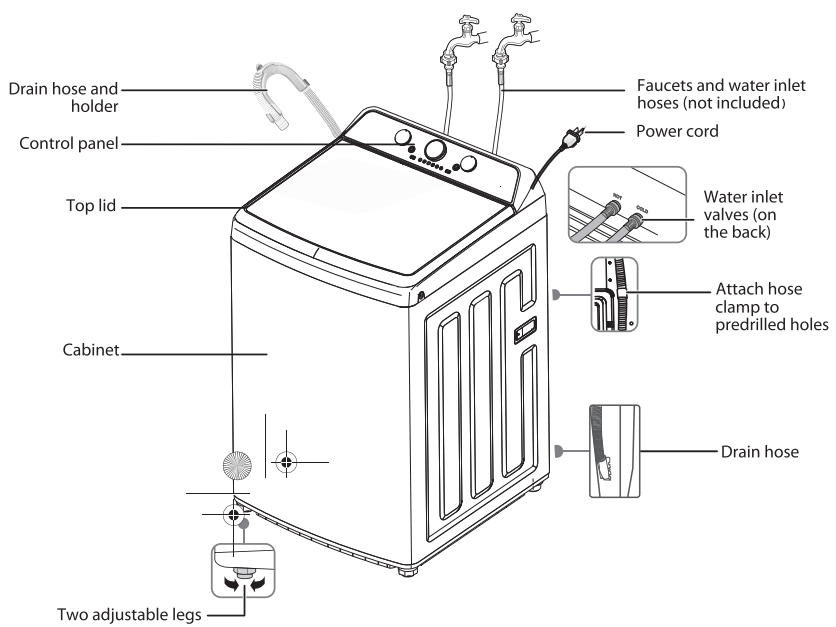

OPERATION REQUIREMENTS

Electrical requirements

WARNING

- To reduce the risk of fire, electric shock, or injury to persons, read the IMPORTANT SAFETY INSTRUCTIONS before operating this appliance.
- Fail to closely follow these instructions may result in an abnormal vibrating and out-of-balance condition that could result in physical injury, damage, and/or appliance damage.

Use a 120 Volt, 60Hz, 15 amp fuse or circuit breaker. We recommend an individual branch circuit that serves only your washer.

WARNING

Never use an extension cord.

Electrical grounding is required for your washer.

You must ground your washer in the event of a malfunction or breakdown, grounding reduces the risk of electric shock by providing a path of least resistance for the electric current.

Your washer is equipped with a power cord with a three-pronged grounding plug for use in a correctly installed and grounded outlet.

The outlet must be correctly installed and grounded in accordance with all local codes and ordinances.

WARNING

- You are responsible for providing adequate electrical services for your washer.
- An incorrectly connected equipment-grounding conductor can increase the risk of electrical shock. Check with a qualified electrician or serviceman if you are not sure whether your washer is grounded correctly.
- Do not modify the power cord plug that came with your washer. If the plug does not fit the outlet, have the correct type outlet installed by a qualified electrician.
- To prevent unnecessary risk of fire, electrical shock or personal injury, all wiring and grounding must be done in accordance with the National Electrical Code ANSI/FNPA, No.70 Latest Revision and local codes and ordinances.
- Never connect the ground wire to plastic plumbing lines, gas lines or hot water pipes.

Water requirements

To fill your washer in the correct amount of time, the water pressure needs to be between 14 and 116 psi (100 to 800 kPa).

If the water pressure is less than 14 psi (100 kPa):

- The water valve may fail or may not shut off completely.
- The time it takes to fill your washer may be longer than the time your washer controls allow. Your washer will turn off and report an error. A time-limit is built into the controls to prevent flooding in your home if a hose becomes loose.
- Water inlet hoses must be purchased separately. You can buy inlet hoses in various lengths up to 8 ft. (240 cm).

To avoid the possibility of water damage:

- Make sure that the water faucets are easily accessible.
- Turn off the faucets when you are not using your washer.
- Periodically check to make sure that water is not leaking from the water hose fittings.

Drainage requirements

The recommended height for the drain standpipe is 48 in. (122 cm).

The drain hose must be routed through the drain hose clip to the standpipe.

The standpipe must be large enough to accept the outside diameter of the drain hose.

INSTALLATION INSTRUCTIONS

Unpacking your washer

WARNING

- Packing materials can be dangerous to children. Keep all packing materials (plastic bags, polystyrene, and so on) well out of the reach of children.
- Do not operate your washer on the foam base cushion. Doing so will result in serious vibration, which could cause equipment damage or result in physical injury.

Remove the packing box and lift the washer up and away from the foam base cushion. Open the lid of the washer to take out all accessories including the protective foam.

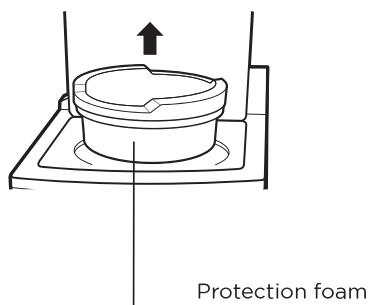
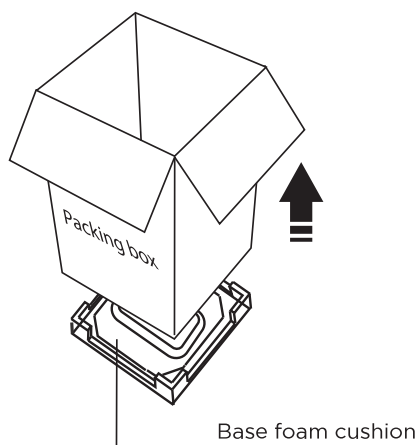

Choosing a location

WARNING

- Do not install your washer in areas where water may freeze, because your washer always retains some water in its water valve, pump and hose areas. Frozen water can damage the valve, pump, hoses and other components.
- Never install on a platform or weakly supported structure.

For best performance, you must install your washer on a solid, level floor.

Wooden floors may need to be reinforced to minimize vibration or unbalanced load situations.

Carpeting and soft tile surfaces can contribute to excessive vibration, which can cause your washer to move slightly during the spin cycle.

Washer dimensions and installation measurements

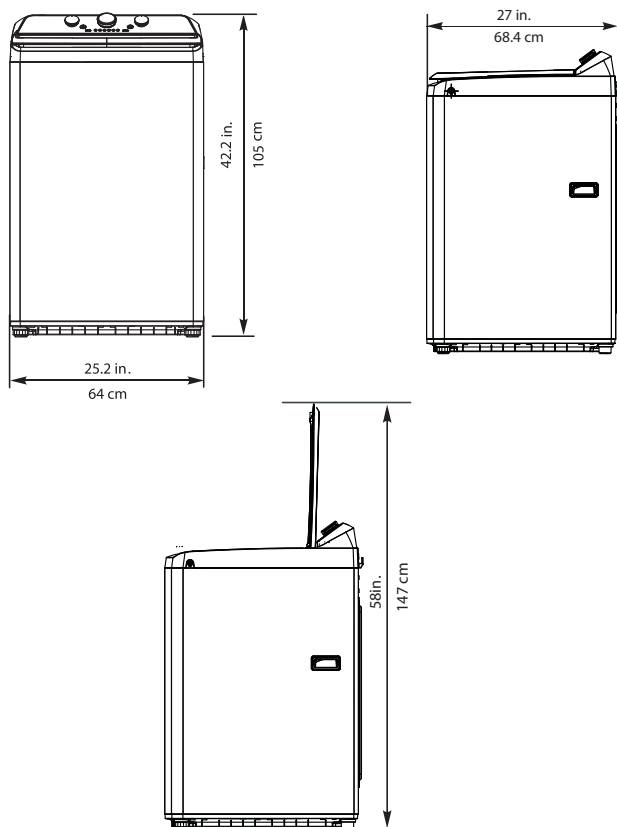

If you install your washer in an alcove or closet, the front of the closet must have two unobstructed air openings for a combined minimum total area of 72 sq.in. (465 sq.cm) with a minimum clearance of 3 in. (7.6 mm) at the top and bottom. A slatted door with equivalent space clearance is acceptable.

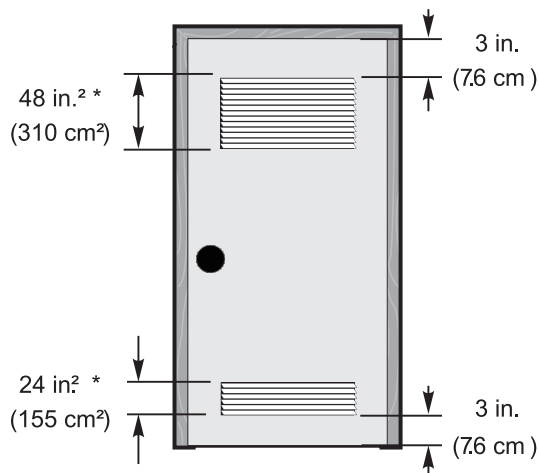

Installing in an alcove or closet

Minimum clearances between your washer and adjacent walls or other surfaces are:

- **Either side:** 1 in. (2.5 cm)
- **Rear:** 6 in. (15.2 cm)
- **Closet Front:** 2 in. (5.1 cm)
- **Top:** 24 in. (61 cm)
- **Gap between the end of water valve and the wall:** 6 in. (15.2 cm)

If you install your washer and dryer side-by-side in a closet, the closet front must have an unobstructed air opening of at least 72 square inches (465 square cm).

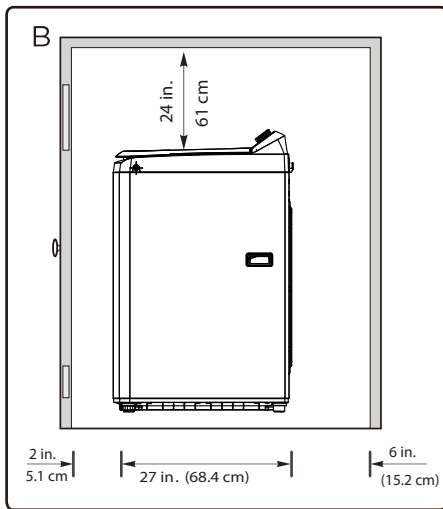
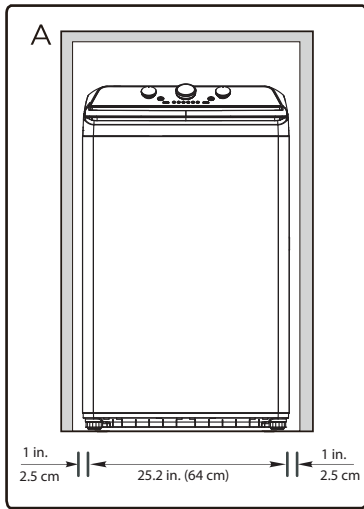

A. Recessed area

B. Side view - closet or confined area

WARNING

- Is a hard, level surface without carpeting or soft flooring that can obstruct ventilation.
- Is away from direct sunlight.
- Has adequate ventilation.
- Is not exposed to freezing temperatures (32 F or 0 C).
- Is away from heat sources such as oil or gas.
- Has enough space so that the washer does not rest on its power cord.

Tools you will need



Pliers



Level

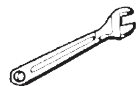

Adjustable
wrench that
opens to 1"
(25 mm)

Connecting the water hoses

NOTE: The water supply hoses are not supplied with your washer and must be purchased separately.

Caution

- Use new water supply hoses. Using old hoses can result in leakage or overflow that can damage your property.
 - Do not connect multiple water supply hoses together to increase the length of the hose. Hoses connected this way can leak and cause electrical shock. If a hose is too short, replace the hose with a longer, high-pressure hose.
1. Make sure that there are rubber washers inside the fittings at both ends of each new water hose. Remove the rubber washers in faucet side and replace with filters. Installing the water supply hoses without rubber washers can cause water leakage.

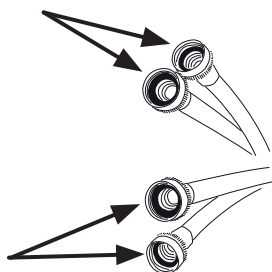

2. Tighten the hose and faucet fittings by hand until they are snug, then tighten them an additional two-thirds of a turn with pliers or a wrench. Pull the water supply hoses downwards to make sure that they are connected securely.

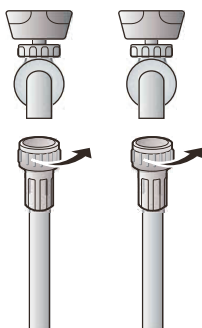

Caution

Do not overtighten the fittings or apply tape or sealant to the faucets or water supply intake. This can damage the fittings.

3. Place the unconnected ends of the hoses into a bucket and turn on the faucets connected to the water supply hoses for 10 or 15 seconds to remove any foreign substances. Turn off the faucets.



4. Connect the ends of the water supply hoses to the water supply intake connections at the top of the washer. Make sure that the rubber washers are in place. The water supply hose connected to the hot faucet must be connected to the hot water supply intake and the water hose connected to the cold faucet must be connected to the cold water supply intake.

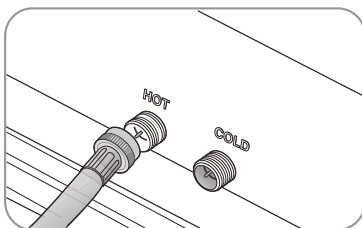

NOTE: If you do not want to use the hot water supply hose, insert a water intake cap into the hot water supply intake hole. In this case you must select the Tap Cold option for the water temperature.

NOTE: No intake cap is provided with your washer. It must be purchased separately.

5. Tighten the fittings by hand until they are snug, and then tighten them an additional two-thirds of a turn with a pliers.

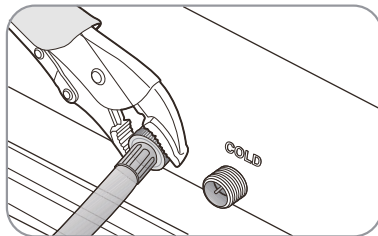

Caution

- Do not overtighten the fittings or apply tape or sealant to the faucets or water supply intakes. This can damage the fittings.
- Make sure that the water supply hoses are not twisted or bent. A bent or twisted hose can leak and cause an electric shock due to the water leakage. To ensure the correct water usage, connect both hot and cold water faucets. If either or both are not connected, an error code could occur.

6. Turn on the hot and cold water supplies and check all the water supply intake connections and the faucets for water leaks.

Connect the drain hose

1. Put the Drain Hose out of the Clamp.
2. Position the other end of the drain hose.
It can be positioned in three ways.

Caution

Make sure that the connection between the drain hose and the wash basin, standpipe or laundry tub is not airtight.

- **Over the edge of wash basin** - Secure the guide to the side of the basin wall with a hook, tape it or tie it with a piece of cord to prevent the drain hose from moving.

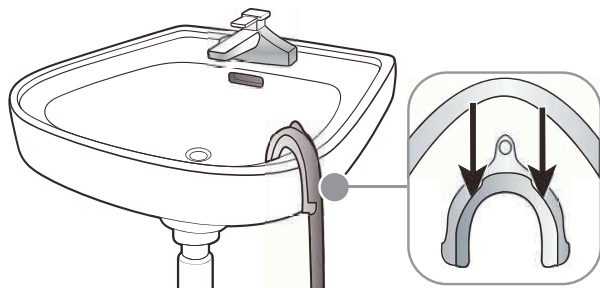

- **In a standpipe** - The standpipe must be no shorter than 39 in. (99 cm) and no longer than 96 in. (244 cm).

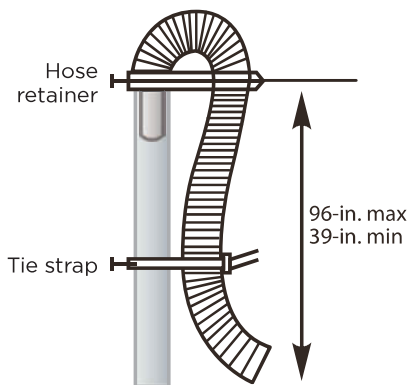

- **In a laundry tub** - The laundry tub must be no shorter than 39-in. (99 cm) and no higher than 96-in. (244 cm) maximum.

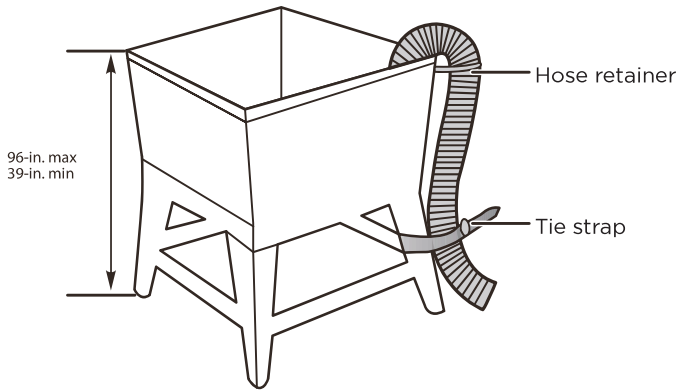

Level your washer

Caution

Do not use your washing machine without leveling. If your washer is not level, it may:

- Vibrate excessively which can cause your washer to malfunction.
- Make excessive noise.
- Indicate error codes when the washer is running.

Extend the leveling feet only as much as is necessary. If the feet are extended too much, your washer may vibrate.

Determine if the washer is level by checking the position of the tub or by using a level.

1. Slide the washer into position.
2. Open the lid of the washer, then pour water into the tub to the leveling circle. If the washer is level, the water will touch the leveling circle all the way around. If the washer is not level, the water will only touch part of the leveling circle.

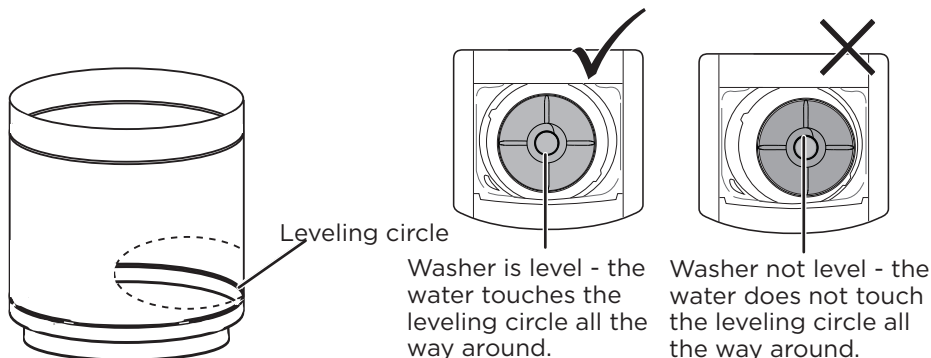

3. If your washer is not level, carefully tilt your washer just enough to adjust the leveling feet on the bottom front of your washer. Extend the feet only as much as is necessary. If the feet are extended too much, your washer may vibrate

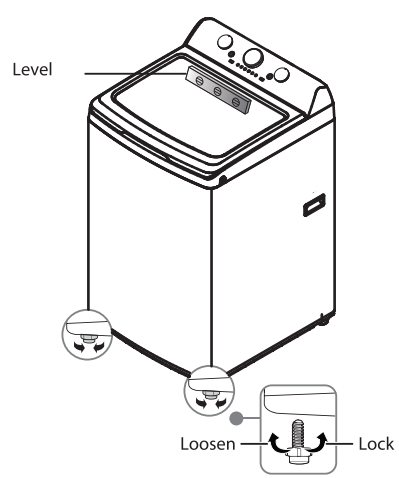

Power on

Plug the power cord into a well-grounded, 3-prong, 120 Volt 60 Hz approved electrical outlet, protected by a 15-amp fuse or comparable circuit breaker. Your washer is grounded through the third prong of the power cord.

Run a test cycle

Run a test cycle to make sure that your washer is properly installed.

1. Load about 6 pounds (2.7 kg) of laundry into the tub.
2. Select the **Cycles** knob to turn on your washer.
3. Press the **Start Pause** button to start the test cycle. Your washer should not rock or vibrate excessively when water fills the tub or when washing or spinning. The washer should drain well during the spin cycle.



Caution

- If you detect any water leaks while the washer is filling or draining, check the water connections. See **Connect the water hoses** on page 19 or **Connect the drain hose** on page 21.
- If the washer rocks and/or vibrates excessively, level it again. See **Level your washer** on page 23.
- The electrical valve, retractor, motor and drain pump of this appliance are intentionally not grounded and may present a risk of electric shock during serving. Do not contact these electronic devices while the appliance is energized.

WASHER USE

Control panel

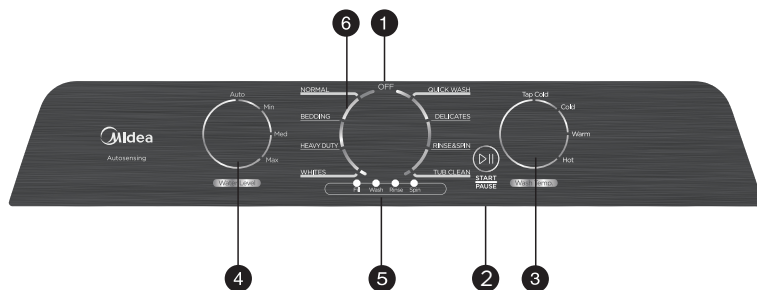

1 Off Button

Turn to select Off to turn off your washer.

2 ▶||/Start Pause Button

Press once to start the wash cycle. Press again to pause the cycle. If you pause the cycle, you can add or remove items, but you cannot change any settings. Press again to restart the cycle.

3 Wash Temp. Select

Turn to select the washing water temperature. The rinse water temperature is always cold.

4 Water Level Selector

Turn to select the water level selector, increase one water level.

5 Cycle status lights

Flash to indicate what part of the cycle your washer is in. For example, the Soak Flash turns on when your washer is in the Soak process.

6 Cycle Selector

Turn to select a wash cycle. The cycle you select determines the wash pattern for the cycle. For more information, see Washer options and setting on page 25.

Washing a load of laundry

WARNING

To reduce the risk of fire, electric shock, or injury to persons, read the **SAFETY INSTRUCTIONS** before operating this appliance.

Selecting a detergent

Your washer is designed to use high efficiency (HE) detergents.

- For the best cleaning results, use an HE detergent. We recommend that you do not use a regular detergent. HE detergents contain suppressors that reduce or eliminate suds. When fewer suds are produced, the load tumbles more efficiently and cleaning is maximized.
- Reducing the amount of detergent may reduce the quality of cleaning. Make sure that you:
 - Pre-treat stains.
 - Sort carefully by color and soil level.
 - Avoid overloading.

1. Turn on your washer

- Your washer will run with cycle selections you choose.
- The lights will display different combinations according to the different cycles you choose.

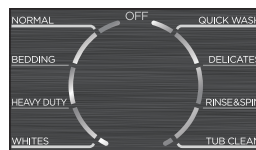

2. Load your washer

Caution

Before loading your laundry, make sure that you remove coins, keys, and other hard objects and close zippers. These items may damage clothes and the washer.

- Sort laundry by fabric type, soil level, color, and load size.
- The wash drum may be fully loaded with loosely added items.

NOTE:

- Overloading may reduce washing efficiency, cause excess wear, and possibly cause creasing or wrinkling of the load.
- Wash delicate items such as bras, hosiery and other lingerie on the **Delicates** cycle with similar lightweight items.

Loading Examples

WORKWEAR	LINENS	MIXED LOAD	DELICATES	QUICK WASH (less than 6 lb)
5 Jeans 5 worker Wear Shirts 3 Woork Wear Pants	2 Bath Sheet 8 Bath Towels 10 Washcloths 6Hand Towels 2 Terrycloth Bath Mat OR 2 Flat Queen-Sized Sheet 2 Fitted Queen-Sized Sheet 4 Pillowcases	3 Pillowcases 3Hand Towel 1Flat Sheet/ 1Fitted Sheet 4Bath Towels/ 4 Washcloths OR 6 Shirts (Men's or Women's) 4Pair Pants (Khakis or Twills) 4 T-shirts 4Pairs of Boxers 3 Pairs of Shorts OR 6 T-shirts 3 Pairs of Shorts 3 Sweatshirts 2 Hoodie 8 Pairs of Socks	6 Bras 6 panties 3 Slips 2Camisole 5 Nightgowns	4 Casual Wear Work Shirts 2 pair Casual Wear Work Pants OR 6 Soccer Uniforms

NOTE:

- Overloading may reduce washing efficiency, cause excess wear, and possibly cause creasing or wrinkling of the load.
- Wash delicate items such as bras, hosiery and other lingerie on the **Delicates** cycle with similar lightweight items.

- When washing big, bulky items (such as rugs or pillows) or a few smaller items (such as stuffed toys or one or two sweaters) that do not fill the tub completely, add a few towels to improve spin performance.
- Always use the **Bulky** cycle for bulky items.
- When washing heavily soiled loads, do not overload your washer to ensure good cleaning results.

3. Add detergent and additives to the compartment

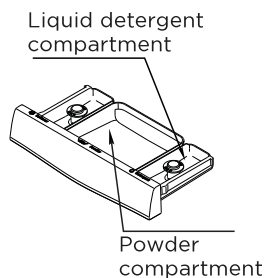

Loading the liquid or powder detergent compartment

- Loading liquid or powder detergent in the compartment indicated.
- Pour the recommended amount of laundry detergent directly into the compartment before starting your washer.
- If you are using color-safe bleach, add it with the detergent to the detergent compartment.

NOTE:

- When adding color-safe bleach with detergent, both laundry products should be in the same form (liquid).
- If no detergent compartment, you should add the detergent into the tub.

Loading PODs in the washer

- First load PODs directly the bottom of an empty basket
- Then add clothes on top of the PODs

NOTE:

- Loading PODs at the bottom of the basket will improve wash performance and will enable detergent to dissolve more easily in the wash.

Bleach compartment

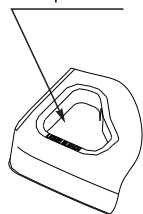

Loading the bleach compartment (liquid bleach only)

- Add chlorine bleach to the bleach compartment. Do not over-fill the compartment.
- There is no water inlet to the bleach dispenser, so the bleach will directly load into the tub when you pour it in.

Caution

- Avoid splashing or over-filling the compartment.
- Never pour undiluted liquid chlorine bleach directly onto the load or into the tub. Doing so can damage fabrics, by weakening of the fibers or stripping the color.

NOTE: Do not pour color-safe bleach into the bleach compartment. Instead, add it to the detergent compartment.

Loading the fabric softener compartment

- Pour the recommended amount of liquid fabric softener into the softener compartment.
- The dispenser automatically releases liquid fabric softener at the correct time during the rinse cycle.
- Whenever fabric softener is used, please make sure to select FABRIC SOFTNER on the Rinse selector knob.



Caution

- Use the softener compartment **ONLY** for liquid fabric softeners.
- Do not use the **Downy Ball®** in the fabric softener compartment.
- Do not use liquid fabric softener that is too thick as it may not mix with the water sufficiently.
- Be sure to select the Fabric Softener option when using fabric softener so that it is released in the rinse portion of the cycle.

4. Add detergent and additives to the compartment

- Turn the cycle selector to select a washing cycle. For information on wash cycles, see Washer options and settings on page 32.

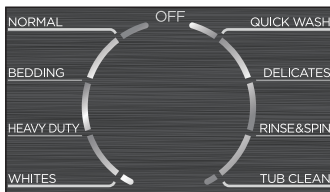

5. Start your washer

- Press the **Start Pause** button.

NOTE:

- As your washer moves from stage to stage in the wash cycle, the related light turns on (such as **Rinse** or **Spin**).



- If you need to pause the cycle (for example to add or remove items or adjust the load), press the **Start Pause** button, then open the lid. Your washer stops. When you are ready to resume washing, close the door, then press the **Start Pause** button.

5. Upload your laundry

When the wash cycle is complete:

- When the wash cycle is complete.
- Open the lid and remove the laundry.

Washer options and settings

- Double beep when button pressed means option not livable for the cycle.

Options and settings table of MLTW47A5BWW/MLTW47A5BGG

- For best washing performance, we suggest the loading weight be less than 17.64 lbs. (8.0 kg) (Dry clothes)
- Bolded options are initial settings. (dots) indicate optional functions you can select.

Program	Water Level	Temp.	Rinse Times
Normal	Auto/1-3	TapCold/Cold/Warm/Hot	1
Quick Wash	2	TapCold/Cold/Warm/Hot	1
Delicates	2	TapCold/Cold/Warm/Hot	1
Rinse&Spin	Auto/1-3	TapCold	1
Tub Clean	3	Hot	1
White	Auto/1-3	TapCold/Cold/Warm/Hot	2
Heavy Duty	Auto/1-3	TapCold/Cold/Warm/Hot	2
Bedding	Auto/1-3	TapCold/Cold/Warm/Hot	2

WASHER CARE

Caution

Turn off the water faucets after final use. This shuts off the water supply to your washer and prevents the possibility of damage from escaping water. Leave the lid open to let the inside of your washer dry out.

Cleaning and Maintenance

Cleaning the exterior

Use a soft cloth to wipe up all detergent, bleach, or other spills as they occur.

Cleaning the interior

- Clean the interior of your washer periodically to remove any dirt, soil, odor, mold, mildew, or bacterial residue that may remain in your washer as a result of washing clothes.
- Failure to follow these instructions may result in unpleasant conditions, including odors or permanent stains in your washer or on your laundry.
- To remove hard water deposits, use a cleaner labeled "Washer safe".

Cleaning the control panel

- Clean with a soft, damp cloth. Do not use abrasive powders or cleaning pads.
- Do not spray cleaners directly on the panel. The control panel finish may be damaged by some laundry pre-treatment soil and stain remover products. Apply such products away from your washer and wipe up any spills or over-spray immediately.

Cleaning the detergent, bleach, or softener compartment

- Clean with a soft, damp cloth. Do not use abrasive powders or cleaning pads.
- Do not spray cleaners directly on the panel. The control panel finish may be damaged by some laundry pre-treatment soil and stain remover products. Apply such products away from your washer and wipe up any spills or over-spray immediately.

Cleaning the tub

The **Self Clean** cycle is a self-cleaning cycle that removes the causes of odors that may occur inside your washer without using a cleaning agent. We suggest cleaning the tub about once a month.

WARNING

The electrical valve, retractor, motor and drain pump of this appliance are intentionally not grounded and may present a risk of electric shock during serving. Do not contact these electronic devices while the appliance is energized.



Caution

Never use the tub clean cycle when laundry is in your washer. This may damage the laundry or your washer.

- With the tub empty, add one cup of chlorine bleach to the bleach dispenser.
- Turn the control knob to power on.
- Turn the cycle selector to **TUB**. With the tub empty, add one cup of chlorine bleach to the bleach dispenser.
- Press the **Start Pause** button.

Storing your washer

You can damage your washer if you do not remove water from hoses and internal components before storage.

To prepare your washer for storage:

- Select the **Quick Wash** cycle and add bleach to the washer. Run your washer through the cycle without a load.
- Turn the water faucets off and disconnect the inlet hoses.
- Unplug your washer from the electrical outlet and leave your washer lid open to let air circulate inside the tub.



Caution

If your washer has been stored in below-freezing temperatures, allow time for any leftover water in your washer to dry out before use.

BEFORE YOU CALL FOR SERVICE...

Troubleshooting Tips

Save time and money! Review the charts on the following pages first and you may not need to call for service.

Problem	Solution
Washer does not start	<ul style="list-style-type: none">• Make sure that your washer is plugged in.• Make sure that the lid is closed.• Make sure that the water source faucets are open.• Make sure that you press the Start Pause button to start your washer.• Before your washer starts to fill, it makes a series of clicking noises to make sure that the lid is locked. The washer doesn't drain after the lid locks. For automatic cycles: Before filling, and after the lid locks, a load sensing program starts. Washer will agitate clothing without water to determine load type, water level, and cycle time. Then it fills. This can take up to one minute. Its normal. For non automatic cycles the washer fills after the lid locks.• Check the fuse or reset the circuit breaker.
No water or not enough water	<ul style="list-style-type: none">• Make sure that both faucets are fully turned on.• Make sure that the water pressure is in the range listed in Water requirements on page 14.• Make sure that the water inlet hoses are not kinked. Straighten if necessary.• Disconnect the hoses and clean the screens. The hose filter screens may be clogged.• This is a water efficiency washer. It does not fill to the levels of a standard washer. Low water levels are normal. It is normal for parts of clothing to stick out of the water.• For automatic cycles: Before filling, and after the lid locks, a load sensing program starts. Washer will agitate clothing without water to determine load type, water level, and cycle time. Then it fills. This can take up to one minute. Its normal. For non automatic cycles the washer fills after the lid locks.

Problem	Solution
When washer has excessive vibration or noise	<ul style="list-style-type: none"> • Make sure that your washer is set on a level surface. If the surface is not level, adjust your washer's feet to level your washer. • Make sure that your washer is not touching any other object. • Make sure that the laundry load is balanced. • During the spin process, if clothes are piled to one side of the tub, your washer may stop because of the imbalance. Your washer tries up to three times to solve the problem automatically. If the washer cannot solve the problem, try to manually redistribute clothes inside the tub. • Check to make sure packaging pieces of base foam cushion are not stuck under washer.
Washer stops	<ul style="list-style-type: none"> • Make sure that the power outlet is a working outlet. • Check the fuse or reset the circuit breaker. • Close the lid, then press the Start Pause button to start your washer. For your safety, your washer does not spin unless the lid is closed. • Before your washer starts to fill, it makes a series of clicking noises to make sure that the lid is locked. The washer doesn't drain after the lid locks. For automatic cycles: Before filling, and after the lid locks, a load sensing program starts. Washer will agitate clothing without water to determine load type, water level, and cycle time. Then it fills. This can take up to one minute. Its normal. For non automatic cycles the washer fills after the lid locks. • Sometimes your washer may pause between stages in the cycle. Wait to see if your washer starts again. • Disconnect the inlet hoses and clean the screens periodically. The hose filter screens may be clogged.
Lid is locked or will not open	<ul style="list-style-type: none"> • Press the Start Pause button to pause the washer. You cannot open the lid if the washer is running. • After you pause the washer, it may take a few seconds for the lid lock to release. • If the lid is locked when your washer is not running, press the Power button to turn on your washer. • If power fails while your washer is running, when power is restored, the lid unlocks. Your washer waits three minutes then runs the rest of the cycle.

Problem	Solution
Washer does not drain or spin	<ul style="list-style-type: none"> • Check the fuse or reset the circuit breaker. • Close the lid, then press the Start Pause button to start your washer. For your safety, your washer does not spin unless the lid is closed. • Make sure that the drain hose is not kinked. Straighten as necessary. Make sure that the height of the drain hose is within specified limits. See Drainage requirements on page 14. • The pipes to your sewer system may be clogged. Contact a plumber or qualified repair professional.
Washer does not drain or spin	<ul style="list-style-type: none"> • Make sure that you have selected the correct temp. • Make sure that the water source faucets are fully opened. • Make sure that the hoses are connected to the correct faucet and water intake connections on your washer, then flush the lines. See Connect the water hoses on page 19. • Disconnect the hoses and clean the screens. The hose filter screens may be clogged.
Load is too wet at the end of the cycle	<ul style="list-style-type: none"> • Use a high-efficiency detergent to reduce over-sudsing. See Selecting a detergent on page 28. • The load may be too small. Very small loads (one or two items) may become unbalanced and not spin out completely.
Water leaks	<ul style="list-style-type: none"> • Make sure that all hose connections are tight. See Connect the water hoses on page 19 and Connect the drain hose on page 21. • Make sure that the end of the drain hose is correctly inserted and secured to the drainage system. See Connect the drain hose on page 21. • Avoid overloading. • Use a high-efficiency detergent to reduce over-sudsing. See Selecting a detergent on page 28.
Oversuds condition	<ul style="list-style-type: none"> • Use a high-efficiency detergent to reduce over-sudsing. See Selecting a detergent on page 28. • If you have "soft" water, reduce the amount of detergent. • For small or lightly soiled loads, reduce the amount of detergent.
Prevent odor	<ul style="list-style-type: none"> • Periodically run a Tub Clean cycle to clean the tub. See Cleaning the tub on page 33. • Use a high-efficiency detergent to reduce over-sudsing. Excessive suds collect in nooks and crannies and cause odor. See Selecting a detergent on page 28. • Dry the interior of your washer after the total cycle has finished.

Error Codes

Your washer is equipped with an automatic error-monitoring system to detect and diagnose problems.

Error Code	Possible Cause	Solutions
○○○○●	Water is not supplied.	<ul style="list-style-type: none"> •Make sure the water taps are open. •Make sure the water hoses are not clogged. •Make sure the water taps are not frozen. •Make sure the washing machine is operating with sufficient water pressure. •Make sure that the cold water tap and the hot water tap are properly connected. •Clean the mesh filter as it may be clogged.
	The Water Level sensor is not working properly.	<ul style="list-style-type: none"> •Check WaterLevel Sensor wire harness. •If the information code remains, Call service center.
○○○○○	Water is not draining.	<ul style="list-style-type: none"> • Make sure the drain hose is not frozen or clogged. • Make sure the drain hose is positioned correctly, depending on the connection type. • Clean the debris filter as it may be clogged. • Make sure the drain hose is straightened all the way to the drain system. • If the information code remains, Call service center.
○○○○●	The lid is open.	<ul style="list-style-type: none"> •Close the lid. See Installation instructions to, "Level your washer". •The door lock or PCB may have failed, try steps again. •If the information code remains, Call service center.
○○○○○	Spinning does not work.	<ul style="list-style-type: none"> • Make sure laundry is spread out evenly. •Make sure the washing machine is on a flat, stable surface. •Redistribute the load. If only one item of clothing needs washing, such as a bathrobe or pair of jeans, the final spin result might be unsatisfactory.
●●●●●	The unit is out of balance in spin operation.	<ul style="list-style-type: none"> •Adjust the washer level refer to installation instructions. •If situation continues, call service center
●○○○○	Load sensing failed.	•Call service center.
●●○○○	Water Leveling sensing failed.	•Call service center.

Notice:

1.LED Display:

1)When error happening, Extra Rinse LED will flash and Process LED indicates error code.

2)○-off, ●-flash, ●-on

2.When error happening, the buzzer will beep 5 seconds and repeat once per 15minutes. After 24 hour, machine will power off automatically.

3.When other error happening, please try again first, call up service line if there are still troubles.

MIDEA LAUNDRY DRYER LIMITED WARRANTY

ATTACH YOUR RECEIPT HERE. PROOF OF PURCHASE IS REQUIRED TO OBTAIN WARRANTY SERVICE.

Please have the following information available when you call the Customer Service Center:

- Name, address and telephone number
- Model number and serial number
- A clear, detailed description of the problem
- Proof of purchase including dealer or retailer name and address

IF YOU NEED SERVICE:

1. Before contacting us to arrange service, please determine whether your product requires repair. Some questions can be addressed without service. Please take a few minutes to review the Troubleshooting section of the User Manual, or visit <http://CanadaSupport@midea.com>
2. All warranty service is provided exclusively by our authorized Midea Service Providers, in Canada.

Midea Customer Service

In Canada, call 1-888-365-2230 or email CanadaSupport@midea.com.

If outside the 50 States of the United States or Canada, contact your authorized Midea dealer to determine whether another warranty applies.

LIMITED WARRANTY

WHAT IS COVERED

FIRST YEAR LIMITED WARRANTY (PARTS AND LABOR)

For one year from the date of purchase, if this major appliance is installed, operated and maintained according to instructions attached to or furnished with the product, Midea America (Canada) Corp. (hereafter "Midea") will pay for factory specified replacement parts and repair labor to correct defects in materials or workmanship that existed when this major appliance was purchased, or at its sole discretion replace the product. In the event of product replacement, your appliance will be warranted for the remaining term of the original unit's warranty period.

LIFETIME LIMITED WARRANTY (STAINLESS STEEL TUB)

For the lifetime of the product from the date of original purchase, when this major appliance is installed, operated and maintained according to instructions attached to or furnished with the product, Midea will pay for factory specified parts and repair labor for the following components to correct non-cosmetic defects in materials or workmanship that existed when this major appliance was purchased:

- Stainless steel tub

YOUR SOLE AND EXCLUSIVE REMEDY UNDER THIS LIMITED WARRANTY SHALL BE PRODUCT REPAIR OR REPLACEMENT AS PROVIDED HEREIN. Service must be provided by a Midea designated service company. This limited warranty is valid only in the 50 States of the United States or Canada and applies only when the major appliance is used in the country in which it was purchased. This limited warranty is effective from the date of original consumer purchase. Proof of original purchase date is required to obtain service under this limited warranty.

LIMITED WARRANTY

WHAT IS NOT COVERED

1. Commercial, non-residential or multiple-family use, or use inconsistent with published user, operator or installation instructions.
2. In-home Instruction on how to use your product.
3. Service to correct improper product maintenance or installation, installation not in accordance with electrical codes or correction of household electrical system (i.e. house wiring, fuses, etc.).
4. Consumable parts (i.e. light bulbs, batteries, air or water filters, etc.).
5. Defects or damage caused by the use of non-genuine Midea parts or accessories.
6. Damage from accident, misuse, abuse, fire, floods, electrical issues, acts of God or use with products not approved by Midea.
7. Repairs to parts or systems to correct product damage or defects caused by unauthorized service, alteration or modification of the appliance.
8. Cosmetic damage including scratches, dents, chips, and other damage to appliance finishes unless such damage results from defects in materials and workmanship and is reported to Midea within 30 days.
9. Routine maintenance of the product.
10. Products that were purchased "as is" or as refurbished products.
11. Products that have been transferred from its original owner.
12. Discoloration, rust or oxidation of surfaces resulting from caustic or corrosive environments including but not limited to high salt concentrations, high moisture or humidity or exposure to chemicals.
13. Pick-up or delivery. This product is intended for in-home repair.
14. Travel or transportation expenses for service in remote locations where an authorized Midea servicer is not available.
15. Removal or reinstallation of inaccessible appliances or built-in fixtures (i.e. trim, decorative panels, flooring, cabinetry, islands, countertops, drywall, etc.) that interfere with servicing, removal or replacement of the product.
16. Service or parts for appliances with original model/serial numbers removed, altered or not easily identified.

The cost of repair or replacement under these excluded circumstances shall be borne by the customer.

DISCLAIMER OF IMPLIED WARRANTIES

IMPLIED WARRANTIES, INCLUDING ANY IMPLIED WARRANTY OF MERCHANTABILITY OR IMPLIED WARRANTY OF FITNESS FOR A PARTICULAR PURPOSE, ARE LIMITED TO ONE YEAR OR THE SHORTEST PERIOD ALLOWED BY LAW. Some states and provinces do not allow limitations on the duration of implied warranties of merchantability or fitness, so this limitation may not apply to you. This warranty gives you specific legal rights, and you also may have other rights that vary from state to state or province to province.

DISCLAIMER OF REPRESENTATIONS OUTSIDE OF WARRANTY

Midea makes no representations about the quality, durability, or need for service or repair of this major appliance other than the representations contained in this warranty. If you want a longer or more comprehensive warranty than the limited warranty that comes with this major appliance, you should ask Midea or your retailer about buying an extended warranty.

LIMITATION OF REMEDIES; EXCLUSION OF INCIDENTAL AND CONSEQUENTIAL DAMAGES

YOUR SOLE AND EXCLUSIVE REMEDY UNDER THIS LIMITED WARRANTY SHALL BE PRODUCT REPAIR AS PROVIDED HEREIN. MIDEA SHALL NOT BE LIABLE FOR INCIDENTAL OR CONSEQUENTIAL DAMAGES. Some states and provinces do not allow the exclusion or limitation of incidental or consequential damages, so these limitations and exclusions may not apply to you. This warranty gives you specific legal rights, and you also may have other rights that vary from state to state or province to province.