

Dehumidifier
MAD



SmartHome
Download the app
& activate product



USER MANUAL

MAD20S1QWT \ MAD35S1QWT \ MAD50S1QWT
MAD50PS1QWT-B \ MAD50PS1QWT \ MAD50PS1QGR
MAD50PS1QWT-S



Warning notices: Before using this product, please read this manual carefully and keep it for future reference. The design and specifications are subject to change without prior notice for product improvement. Consult with your dealer or manufacturer for details. The diagram above is just for reference. Please take the appearance of the actual product as the standard.

THANK YOU LETTER

Thank you for choosing Midea! Before using your new Midea product, please read this manual thoroughly to ensure that you know how to operate the features and functions that your new dehumidifier offers in a safe way.

CONTENTS

THANK YOU LETTER	2
SAFETY INSTRUCTIONS	3
SPECIFICATIONS AND FEATURES	7
PRODUCT INSTALLATION	8
OPERATION INSTRUCTIONS	16
APP INSTRUCTIONS	19
CLEANING AND MAINTENANCE	23
TROUBLESHOOTING TIPS	25
WARRANTY	26

SAFETY INSTRUCTIONS

Intended Use

The following safety guidelines are intended to prevent unforeseen risks or damage from unsafe or incorrect operation of the appliance. Please check the packaging and appliance on arrival to make sure everything is intact to ensure safe operation. If you find any damage, please contact the retailer or dealer. Please note modifications or alterations to the appliance are not allowed for your safety concern. Unintended use may cause hazards and loss of warranty claims.

Explanation of symbols



Warning

The signal word indicates a hazard with a medium level of risk which, if not avoided, may result in death or serious injury.



Caution

The signal word indicates a hazard with a low degree of risk which, if not avoided, may result in minor or moderate injury.



Attention

The signal word indicates important information (e.g. damage to property), but not danger.

Read these operating instructions carefully and attentively before using/commissioning the unit and keep them in the immediate vicinity of the installation site or unit for later use!



CAUTION

- For support, please call the Service Center at 1-866-646-4332.
- This appliance is not intended for use by people (including children) with reduced physical, sensory, or mental capabilities or lack of experience and knowledge, unless they have been given supervision or instruction concerning use of the appliance by a person responsible for their safety.
- Children should be supervised to ensure that they do not play with the appliance.
- If the power cord needs to be replaced, please contact our consumer service or an authorized technician.
- Electrical installation, if needed, must be performed in accordance to national wiring regulation by qualified personnel only.
- Do not operate in an excessively humid room such as a bathroom or laundry room

SAFETY MANUAL

FOR R32 REFRIGERANT MODEL



North America Products



CAUTION:
Risk of fire
flammable materials

IMPORTANT NOTE: Read this manual carefully before installing or operating your new air conditioning unit. Make sure to save this manual for future reference.

Explanation of symbols displayed on the unit

	<p>CAUTION</p>	<p>This symbol shows that the operation manual should be read carefully.</p>
	<p>CAUTION</p>	<p>This symbol shows that a service personnel should be handling this equipment with reference to the installation manual.</p>
	<p>CAUTION</p>	<p>This symbol shows that information is available such as the operating manual or installation manual.</p>

WARNING

Please read through these instructions before you start the installation process. Improper installation can cause damage to the unit and/or personal property and can be a personal safety hazard.

- Be sure the dehumidifier has been securely and correctly installed according to the installation instructions in this manual. Save this manual for possible future use in removing or installing this unit.
- Plug in power cord plug properly.
Otherwise, it may cause electric shock or fire due to excess heat generation.
- Do not modify power cord length or share the outlet with other appliances.
It may cause electric shock or fire due to overheating.
- Always ensure effective grounding.
Incorrect grounding may cause electric shock.
- Unplug the unit if strange sounds, smells, or smoke come from it.
A damaged product may cause fire and electric shock.
- Ventilate room before operating the unit if there is a gas leak from other appliances.
- Do not operate or stop the unit by inserting or pulling out the power plug.
It may cause electric shock.
- Do not allow water to enter into electric parts.
It may cause failure or electric shock.
- Do not use the power outlet if it is loose or damaged.
It may cause fire and electric shock.
- Do not use or keep the power cord close to heating appliances or heat sources such as fireplaces.
It may cause fire and electric shock.
- Do not disassemble or modify unit.
It may cause failure and electric shock.
- Do not damage or use an unspecified power cord.
It may cause fire and electric shock.
- If the power cord is damaged, it must be replaced by the manufacturer or an authorized service center or a similarly qualified person in order to avoid electrical risk.
- Do not use the unit near flammable gas or combustibles, such as gasoline, benzene, thinner, etc.
It may cause fire.
- Be sure the dehumidifier has been securely and correctly installed according to the installation instructions in this manual. Save this manual for possible future use in removing or installing this unit.
- Do not operate with wet hands.
It may cause electric shock.
- Do not open the unit during operation.
It may cause electric shock.
- Avoid fire hazard or electric shock.
Do not use an extension cord or an adaptor plug. Do not remove any prongs from the power cord.
- Be sure the dehumidifier is properly grounded. To minimize shock and fire hazards, proper grounding is important.
The power cord is equipped with a three-prong grounding plug for protection against shock hazards.
- Your dehumidifier must be used in a properly grounded wall receptacle. If the wall receptacle you intend to use is not adequately grounded or protected by a time delay fuse or circuit breaker, have a qualified electrician install the proper receptacle. Ensure the receptacle is accessible after the unit installation.
- Be sure the electrical service is adequate for the model you have chosen. This information can be found on the serial plate, which is located on the side of the cabinet and behind the grille.
- Do not drink the water from the bucket.
- Before cleaning, turn off the power and unplug the unit.
- Do not use the unit in small spaces or place in a sink or shower.
Lack of ventilation can cause overheating and fire.
- Do not attempt to repair the unit yourself.
- Make sure the bucket is empty of water before nesting unit.
It could cause electric shock and/or damage the unit.
- Unplug the unit before nesting it in the bucket.
It could cause electric shock and/or damage the unit.
- When unplugging the unit, be sure to grab the plug, not the cord.



CAUTION

- Do not use in places where water may splash onto the unit.
Water may enter the unit and degrade the insulation. It may cause an electric shock or fire.
- Place the unit on a level, sturdy section of the floor.
If the unit falls over, it may cause water to spill and damage belongings, or cause electrical shock or fire.
- Never insert your finger or other foreign objects into grills or openings. Take special care to warn children of these dangers.
It may cause failure or electric shock.
- Do not climb up on or sit on the unit.
You may be injured if you fall or if the unit falls over.
- Always insert the filters securely, and take caution to avoid injuries to hand and fingers. Clean filter once every two weeks.
- If water enters the unit, turn the unit off and disconnect the power, contact a qualified service technician.
- Do not place anything on top of the unit.
This would restrict airflow, possibly damage the unit and decrease performance.
- If the unit is knocked over during use, turn off the unit and unplug it from the main power supply immediately. Visually inspect the unit to ensure there is no damage. If you suspect the unit has been damaged, contact customer service or a qualified technician.
- In a thunderstorm, the power should be disconnected to the unit due to lightning.
- Do not run power cord under carpeting. Do not cover cord with throw rugs, runners, or similar coverings. Do not route cord under furniture or appliances.
Arrange cord away from traffic area and where it will not be tripped over.
- Always lift unit with 2 hands using proper lifting technique.
- Before turning the unit on, make sure it is seated correctly on the bucket.
- Before lifting ensure the handle is properly attached.
- Only use the bucket that came with the unit. Do not use any other bucket.
- Clean the bucket regularly.



WARNING

- Do not try to accelerate the defrosting process or methods of cleaning that are not recommended by the manufacturer.
- The appliance shall be stored in a room without a continuously operating ignition source (for example, open flames or an operating gas appliance) or an ignition source (for example, an operating electric heater) close to the appliance. The appliance shall also be stored in a room without ignition sources.
- Do not pierce or burn.
- Be aware that the refrigerants may not contain an odor.
- Keep ventilation openings clear of obstruction.
- Unit is only to be serviced by a Midea authorized servicer, please call Customer Service at 1-866-646-4332 for support.
- Flammable refrigerant R32 is used within appliance. Please follow the instructions carefully to handle, install, clean, and service the appliance to avoid damage or hazard. Do not dispose of appliance in regular trash. Contact qualified agency for proper disposal.
- No open fire or devices that generate spark/arc shall be around the appliance to avoid causing ignition of the flammable refrigerant used. Please follow the instructions carefully to store or maintain the appliance to prevent mechanical damage from occurring.

SPECIFICATIONS AND FEATURES

Product overview

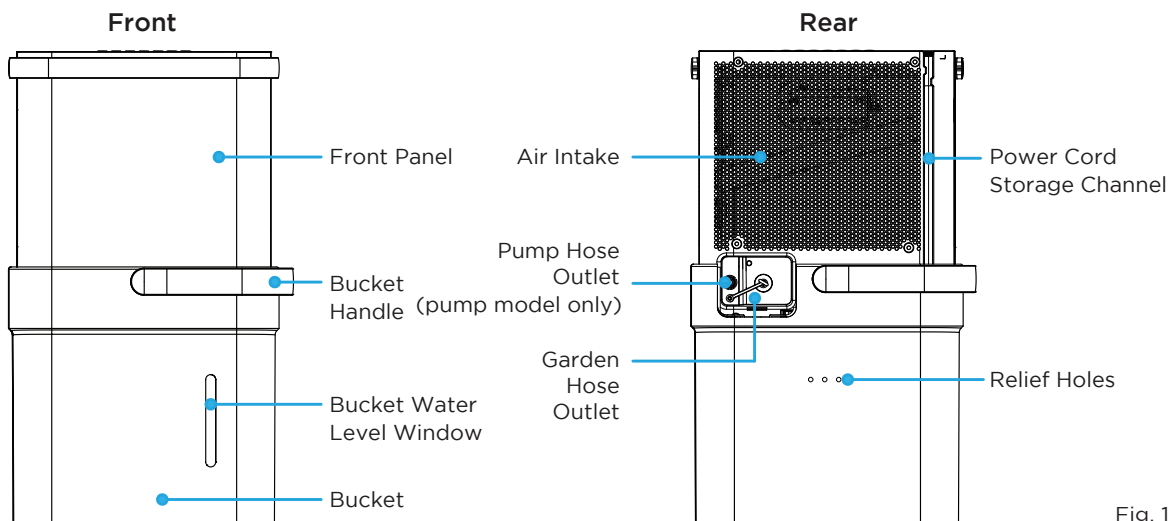

Fig. 1

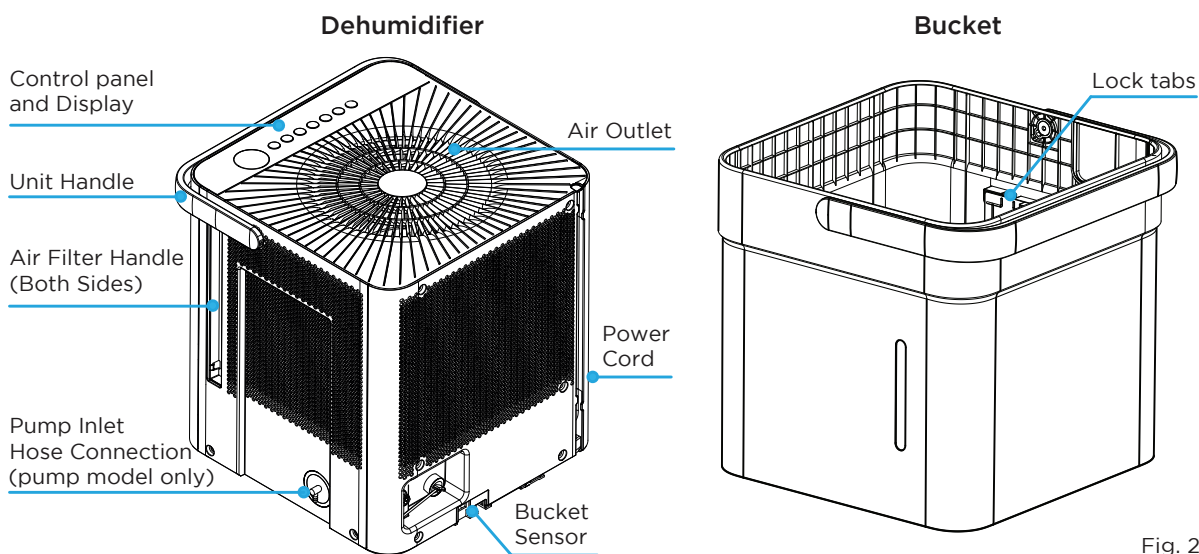

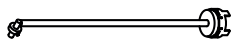
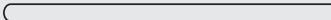

Fig. 2

Accessories

Pump drain hose (only for units with the drain pump feature)	
Pump inlet hose (only for units with the drain pump feature)	
Normal drain hose	

PRODUCT INSTALLATION

Positioning the Unit

The dehumidifier should be placed in the area where dehumidification is desired most. Adjacent rooms in which dehumidification is also desired should allow adequate airflow in and out of the space containing the dehumidifier.

- Do not use outdoors.
- This dehumidifier is intended for indoor residential applications only. This dehumidifier should not be used for commercial or industrial applications.
- Place the dehumidifier on a smooth, level floor strong enough to support the unit with a full bucket of water.
- Allow at least 8" of air space on all sides of the unit for air circulation (at least 16" for air outlet).
- Place the unit in an area where the temperature will not fall below 41°F (5°C). The coils can become covered with frost at lower temperatures, which may reduce performance.
- Place the unit away from any clothes dryer, heater or radiator.
- Close all doors, windows, and other openings to the outdoors in the room.

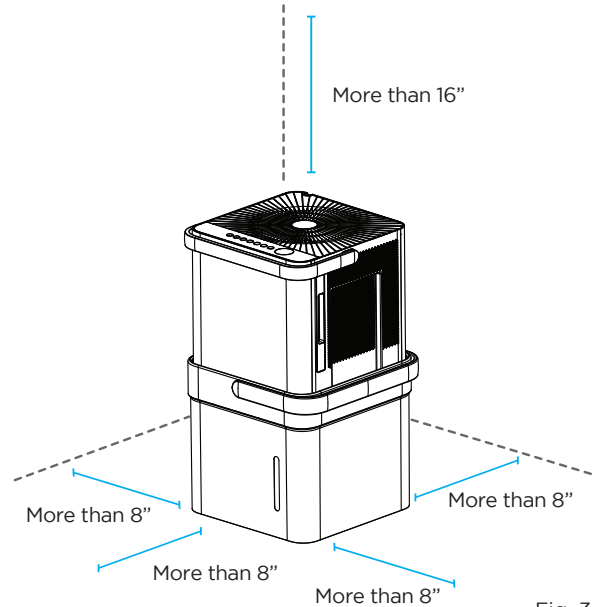

Fig. 3

Optional Caster Installation

To install the casters:

1. Remove the Dehumidifier from the bucket.
2. Slide each caster into the slot on the bucket's bottom corner as shown below.
3. Place the retaining block into the slot to hold the caster in place.
4. Repeat this for each corner of the bucket until all 4 casters are installed.

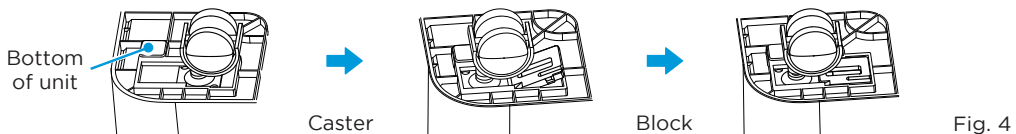

Fig. 4

To remove the casters:

1. Use a flathead screwdriver to actuate the tab on the retaining block.
2. Remove the retaining block and slide the casters out of the slot on the bucket.

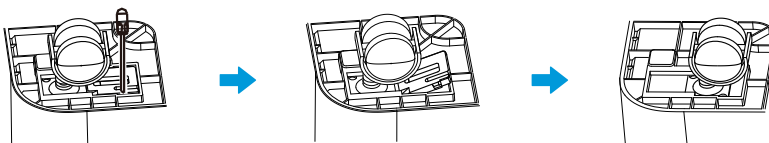

Fig. 5

NOTE

With the casters attached, do not move the unit and bucket assembly while there is water in the bucket. Before rolling the bucket, remove the unit.

Midea Cube Installation Modes and Installation Video

The Midea Cube dehumidifier can be installed in 4 different modes - Bucket Mode, Bucketless Mode, Continuous Draining, and Drain Pump Mode (pump model only)

Scan this QR code with your mobile device to watch an installation video of the Midea Cube that walks through all four installation modes.



Bucket Mode - Set Up Instructions (Install Video Time 0:36)

Step 1:

Separate dehumidifier & bucket from the nested shipping/storage position. Remove all packaging materials from the unit.

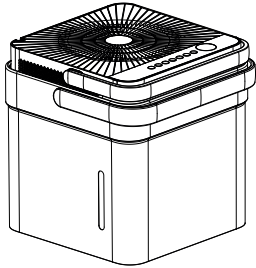

Nested Shipping & Storage Position

Fig. 6a

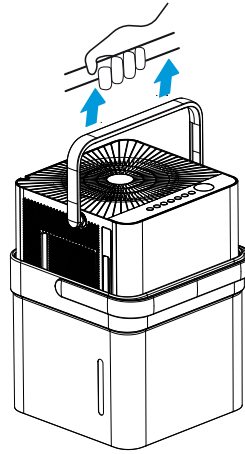

Fig. 6b

Step 2:

Rotate dehumidifier 90° and align the arrows on the two labels (one on the bucket and one on the dehumidifier) and carefully sit the dehumidifier down onto the bucket.

The water level window in the bucket and the user interface buttons on the dehumidifier should be on the same side when properly stacked. Check to ensure the arrows on the unit and bucket are aligned as in Fig. 7c for proper operation.

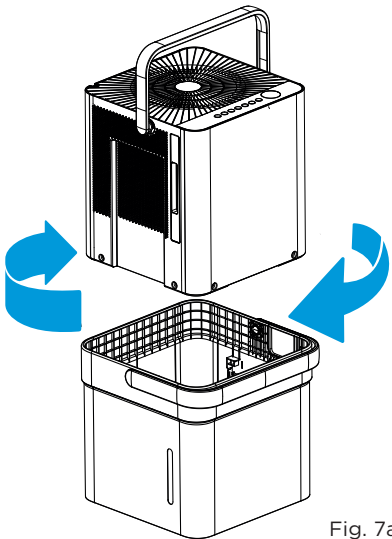

Fig. 7a

Rotate dehumidifier 90°

User Interface Buttons and Water Level Window Aligned on the Same Side

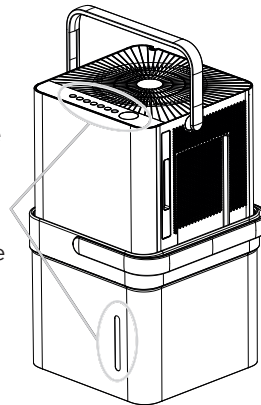

Fig. 7b



Fig. 7c

Step 3:

Plug the unit in and press the power button and the unit is ready to run in normal (bucket) mode.

NOTE

See page 16 for operating instructions.

Emptying the Bucket (Time 2:56)

- When the bucket reaches the set Fill Level, the unit's display will show P2 regardless of power status
- Using proper lifting techniques, remove the unit from the bucket. Be aware, some residual water may spill from the bottom of the unit while not on the bucket.
- Using two hands, grab the bucket handle and carry it to the desired drainage point. Pouring from a front corner of the bucket (the bucket window is on the front side), empty the bucket. If pouring from the back of the bucket, some water may spill from the relief holes.
- Return the bucket to the desired operating location and place the unit back on the bucket. Be sure the unit is aligned properly

1. Lift the unit off the bucket and place it on a level surface.

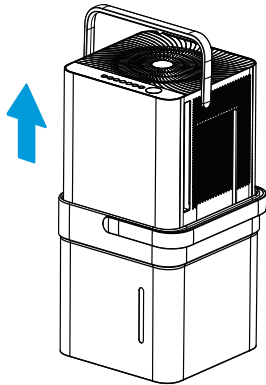

Fig. 8

NOTE

- When you remove the unit from the bucket do not set the unit on any electrical components as the bottom may be wet
- Do not set the unit on an uneven surface after removing it from the bucket
- Ensure the unit is seated properly after returning it to the bucket
- If the unit is removed from the bucket during operation, the display will show the error code Eb and cease operation until returned to the bucket or changed to bucketless mode.

2. Lift the bucket using 2 hands and carry it to a drainage point.
3. Pour out all the water.

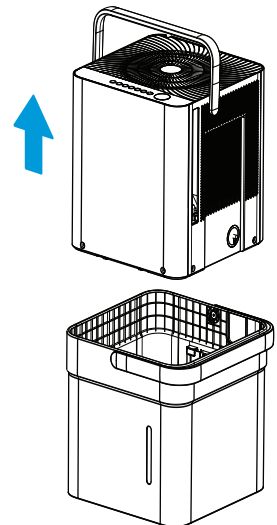

Fig. 9

Bucketless Mode - Set Up Instructions (Install Video Time 3:32)

Bucketless mode allows you to run the unit in continuous drain mode without the bucket in place, best for use in smaller spaces.

NOTE

Bucketless mode must be enabled within 3 minutes of plugging in the dehumidifier, so it is best to set up the unit for this operation before powering on the unit.

Step 1:

Set the unit directly on the surface or floor of the area to be dehumidified. Remove the drain cap from the continuous drain port at the back of the unit.

Remove drain cap by rotating counter-clockwise

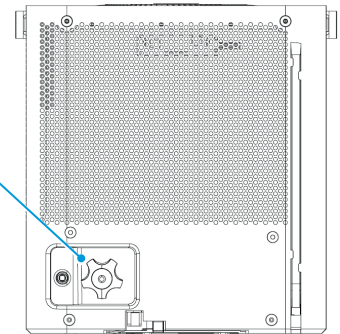

Fig. 10

Step 2:

Insert the continuous drain hose into the continuous drain port at the back of the unit. Set the other end of the hose in the drain, ensuring the hose slopes down and does not raise above the drain port.

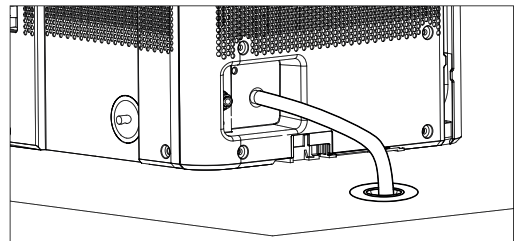

Fig. 11

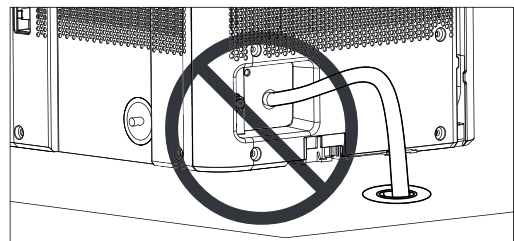

Fig. 12

Step 3:

Plug in the dehumidifier. Press the UP (⤴) and FILL LEVEL buttons simultaneously for 3 seconds. The bucketless mode icon will appear in the bottom right of the display when the unit is ready to operate in bucketless mode (see UI on page 16 for example).

To remove the unit from bucketless mode, place the unit back on the bucket.

NOTE

See page 16 for operating instructions.

Continuous Draining - Set Up Instructions (Install Video Time 4:39)

Step 1:

Before placing the unit on the bucket, remove the continuous drain cover from the back of the bucket. Make sure to keep the cover if you ever plan to change operating modes.

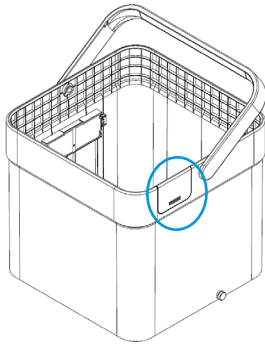

Fig. 13a

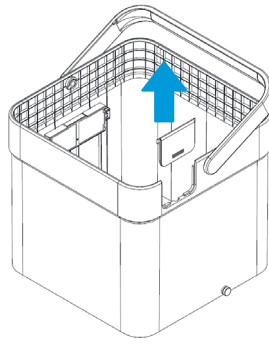

Fig. 13b

Step 2:

Place the unit onto the bucket. Remove the continuous drain plug cover and insert the included continuous drain hose. You can also attach and use a garden hose by screwing it on to the drain port. Check to make sure the hose is properly seated.

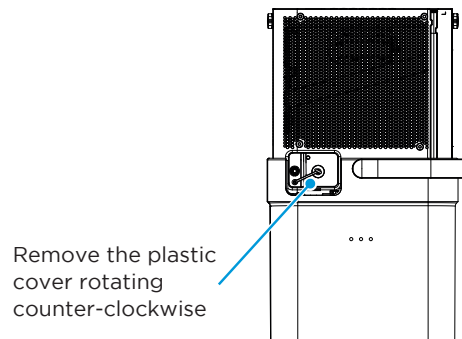

Fig. 14

Step 3:

Place the other end of the drain hose on or in the drain. Ensure the unit is placed at a height where the unit drain port is above the drain hose outlet. This will ensure proper draining.

Note that the bucket fill level LEDs do not operate when the continuous drain hose is installed.

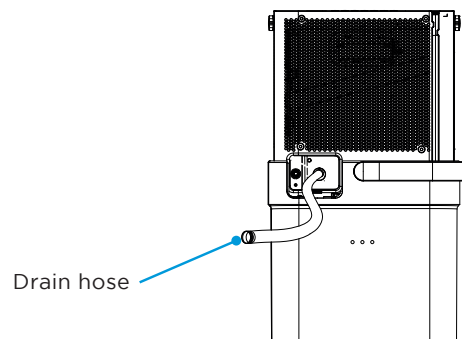

Fig. 15

NOTE

See page 16 for operating instructions.

Drain Pump Mode - Set Up Instructions (Install Video Time 5:43)

Step 1:

Before placing the unit on the bucket, remove the continuous drain cover from the back of the bucket. Make sure to keep the cover if you ever plan to change operating modes.

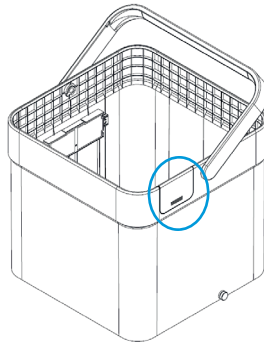

Fig. 16a

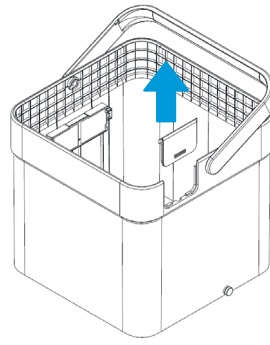

Fig. 16b

Step 2:

Install the pump inlet hose by pressing the hose fitting into the connection located on the side of the unit. Rotate the fitting in the connection 90 degrees to lock it in place and ensure it is fully seated.

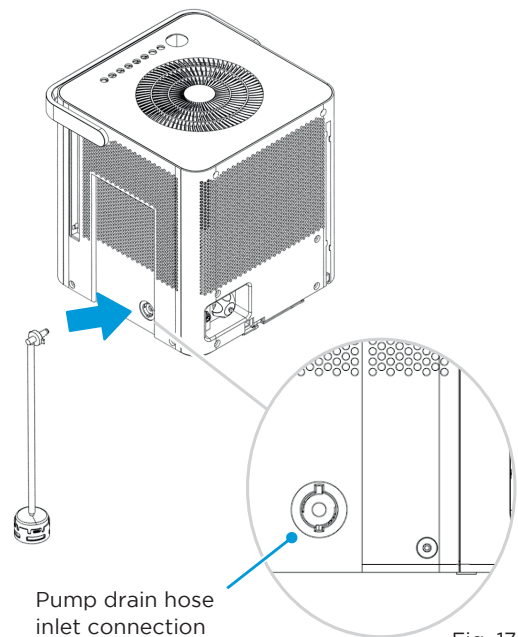

Fig. 17

Step 3:

Lift the dehumidifier and set it onto the bucket. Make sure the unit is properly aligned with the bucket and that the pump sits inside the bucket. The pump must be placed in the bucket in order to pump water out of the bucket.

NOTE

The pump will not activate until the water reaches the level 4 fill level inside the bucket. When the pump stops running, some water will remain in the bucket - this is to keep the pump inlet submerged and prevent the pump from pumping air, which can cause damage to the pump.

Step 4:

Insert the pump drain hose to the back of the dehumidifier, using the connection next to the continuous drain port. Check to make sure the pump drain hose is fully seated in the pump drain connector.

NOTE

To remove the pump hose, push in on the collar around the hose while pulling the hose out.

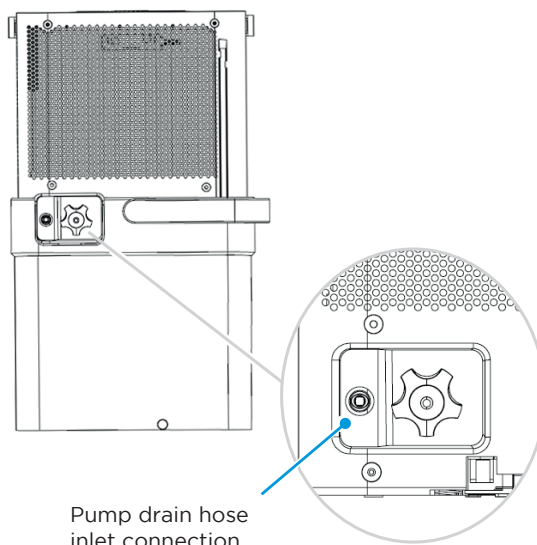

Fig. 18

Step 5:

Set the other end of the pump drain hose in the desired drain location, noting that the pump can pump up to 14 feet above the drain port to an elevated drain location.

Step 6:

Initiate pump mode by pressing the UP (∧) and DOWN (∨) buttons simultaneously for 3 seconds. The pump indicator will appear at the top left of the unit's display when the unit is ready to operate in pump mode (see UI on page 16 for example). Note that the bucket fill level LEDs do not operate when the pump drain hose is installed.

NOTE

The pump may generate a loud noise for the first 3 to 5 minutes of operation.

NOTE

The pump operation light blinks when a failure occurs. Please turn off the unit and disconnect the power cord. Check the following items:

- Cleaning the pump filter.
 - Refer to "Cleaning and Maintenance" section for details on cleaning the pump filter.
- Check if the drain hose is clean and free of debris.
- Empty the water from the bucket.
- Check the hose connection and the bucket for proper fitment. If the error persists, contact customer service.

NOTE

If routing the drain hose outdoors, do not operate when the outdoor temperature is at or below 32°F (0°C) as the water will freeze, blocking the hose and causing the unit to stop.

Make sure to empty the bucket at least once a week when using the pump draining feature. When the pump draining feature is not being used, remove the pump drain hose from the outlet.

OPERATION INSTRUCTIONS

Control Panel Features

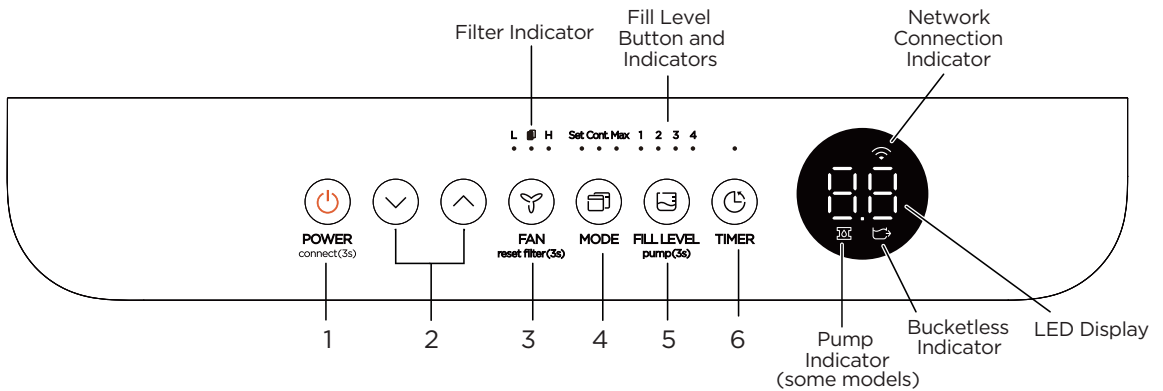

		Description
1	ON / OFF	<ul style="list-style-type: none"> Press to turn unit on or off. Press for 3 sec to initiate smart connection mode.
2	UP / DOWN Buttons	<ul style="list-style-type: none"> Press to set humidity and timer.
3	FAN Button	<ul style="list-style-type: none"> Press to select the Fan Speed in two steps - High and Low. Press for 3 sec to turn off the cleaning filter reminder.
4	MODE Button	<ul style="list-style-type: none"> Press to choose operating mode in a sequence that goes from Set, Max and Cont.
5	FILL LEVEL Button	<ul style="list-style-type: none"> Press this button to change the water level at which the bucket full switch activates. Press for 3 sec to activate pump mode.
6	TIMER Button	<ul style="list-style-type: none"> Press to turn unit Auto Start/Stop.

NOTE

The appearance of the control panel on your unit may vary slightly. Functions will be similar.

NOTE

Control Pads: When you push the button to change operation modes, the unit will make a beep sound to indicate that it is changing modes.

1. POWER BUTTON (ON/OFF):

Press to turn the dehumidifier on and off.

CONNECT:

Holding the power button for 3 seconds will place the unit in network connection mode to setup wireless control.

2. UP (∧) AND DOWN (∨) BUTTONS:

Press these buttons to adjust the setpoint or to set the time feature.

3. FAN BUTTON:

Press this button to change the fan speed between High and Low.

FILTER RESET:

To reset the change filter indicator, hold the fan button for 3 seconds.

4. MODE BUTTON:

Press this button to change the mode of the dehumidifier between Set mode, Max mode, and Continuous run mode.

Set - When the unit is running, the LED display will show the current room humidity. Press either the UP or DOWN button once to see the current set point, and press the UP or DOWN button again to change the set point in 5% increments. The dehumidifier runs until the humidity set point has been reached. The dehumidifier will begin running once the humidity rises above the set point again.

Max - The dehumidifier will run continuously on High Fan.

Continuous - The dehumidifier will run continuously and the fan speed can be changed in this operating mode.

NOTE

While operating on continuous and Max modes, the humidity setpoint cannot be adjusted manually.

5. FILL LEVEL BUTTON:

The FILL LEVEL BUTTON allows you to change the required water level before the bucket full switch activates. Press the FILL LEVEL button once to see the current setting, and press the button again to toggle through the different set levels to adjust the setting. The options will fill approximately to the amounts shown in the table below:

Fill level	Models MAD20S1QWT	Models MAD35S1QWT MAD50S1QWT MAD50PS1QWT MAD50PS1QWT-B MAD50PS1QGR MAD50PS1QWT-S
1	1.5 gallons (17 lb)	2.25 gallons (24 lb)
2	2 gallons (21 lb)	3 gallons (30 lb)
3	2.75 gallons (27.5 lb)	3.75 gallons (36.5 lb)
4	3 gallons (29.5 lb)	4.25 gallons (40.5 lb)

Choose the option which is most comfortable for you when emptying the bucket.

When the bucket is full, the Display will show P2. The weights above are approximate weights of the bucket when filled with the corresponding volume of water.

NOTE

For accurate fill levels, ensure the bucket is empty before beginning operation.

Pump:

Holding the fill level button for 3 seconds will activate pump mode if the bucket is in place (pump model only).

6. TIMER BUTTON:

Press this button to activate the Timer function. The Timer LED will illuminate indicating timer mode is being set. 0.0 will also appear on the display indicating the number of hours from now until the timer function will initiate. When the timer function initiates, the unit will change its power state.

- When activating the Timer function, you are setting the time until the unit changes its power state. This means, if the unit is on, activating the timer function will set the time until the unit will turn off. If the unit is off, activating the timer function will set the time until the unit will turn on.
- The time can be set after pressing the timer button then using the up or down buttons. These buttons will change the time in 0.5 hour increments up to 10 hours. After 10 hours, the time will change in 1 hour increments up to 24.
- If an error code appears during this time, the timer function will be cancelled.

LED Display

Shows the set humidity or auto start/stop time (0 ~ 24h), also shows error and protection codes.



Error Codes and Protection Code:

- AS** - Humidity sensor error - Unplug the unit and plug it back in. If error persists, contact Customer Service.
- ES** - Tube Temperature sensor of the evaporator error - Unplug the unit and plug it back in. If error persists, contact Customer Service.
- P2** - Bucket has reached the set Fill Level – Empty the bucket and place the unit on the bucket properly.
- EC** - Refrigerant leakage detection - Display area will show EC when the unit detects refrigerant leakage. If error persists, contact Customer Service.
- E3** - Unit malfunction - Unplug the unit and plug it back in. If error persists, contact Customer Service.
- Eb** - Bucket is removed or not in right position - Replace the bucket in the right position. (only available for the unit with pump feature.)

Other Features

AUTO DEFROST

When frost builds up on the evaporator coils, the compressor will cycle off and Auto Defrost function will run automatically.

3 MINUTE COMPRESSOR OPERATION DELAY PROTECTION

After the unit has stopped, it can not be restarted in the first 3 minutes to protect compressor operation. The unit will restart automatically after 3 minutes.

AUTO-RESTART

If the unit stops unexpectedly due to power being cut, it will restart with the previous function setting (except bucketless mode) automatically when the power resumes.

NOTE

- When first using the dehumidifier, operate the unit continuously 24 hours. Make sure the plastic cover on the continuous drain hose outlet is installed properly so there are no leaks.
- This unit is designed to operate in a working environment between 5°C/41°F and 35°C/95°F.
- Make sure the water bucket is positioned correctly so that the unit can operate properly. When the water in the bucket reaches a certain level, please be careful while moving the unit to avoid spilling.

APP INSTRUCTIONS

Specification of Wireless Module

Model: US-SK105	Dimensions: 41 x 24 x 5 (mm)
Antenna Type: Printed PCB Antenna	Operation Temperature: 0°C ~ 45°C / 32°F ~ 113°F
Frequency: WLAN 2400-2483.5 MHz	Operation Humidity: 10% ~ 85%
Maximum Transmitted Power: <20 dBm Max	Power Input: DC 5V/300 mA

Precautions

App Compatibility:

- The app is available for both iOS and Android, however older versions may no longer be compatible. Please keep the app updated with the latest version. Midea makes no guarantee of compatibility and is not responsible for issues arising as a consequence thereof.

Wireless Security:

- The Smart Kit supports the following security protocols: WPA-PSK / WPA2-PSK / WPA3-SAE.
- It may be used with or without encryption although encryption is strongly recommended.

Connectivity:

- Network issues may occasionally cause timeouts. The unit display and the app may become unsynchronized but this will resolve itself when the network is restored.
- Should the network remain unavailable, it might be necessary to run the configuration process again.
- Change in the wireless network will require reconfiguration of the device.

Configuration:

- The actual network configuration process may vary slightly from the manual.
- Please check the service website for more information.

NOTE

Midea will not be responsible for any problems that could be caused by incompatibility or network issues, your wireless router and mobile phone.

Using the SmartHome App

CAUTION

Ensure that your mobile phone is connected to the wireless network. Bluetooth must be turned on. The device must also be powered up.

Step 1: Download the SmartHome app

Scan the QR code below to download the SmartHome app from app store or search for it directly on the Google Play Store or Apple's App Store.



Step 2: Log in

Open the SmartHome app. Log in directly if you have an existing SmartHome account or create a new account. Alternatively, you can also use a 3rd party login platform.



Step 3: Connecting the device

1) When you log in, you may see the message "Smart devices discovered nearby". Tap to add your device.

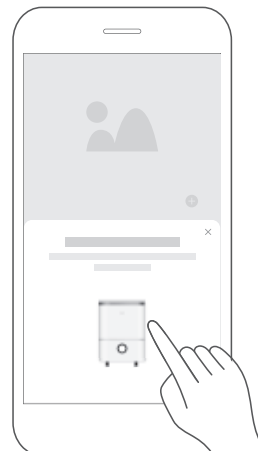

2) If no such message appears, proceed as follows:

Tap on “+” and select your device in the list of nearby available devices.

If your device is not listed, please add your device manually, first selecting the device category e.g. Dehumidifier.



3) Follow the steps in the app to connect your device to the wireless network. If your device fails to connect, follow the additional instructions in the app.



Step 4: Controlling the device

After pairing successfully, a card will be created for the device in the SmartHome app.

Shortcuts for basic functions will appear on the card such as changing the humidity or switching the device on or off.

Tapping on the card, will reveal additional features and settings.

The actual design may look different from examples due to app updates.

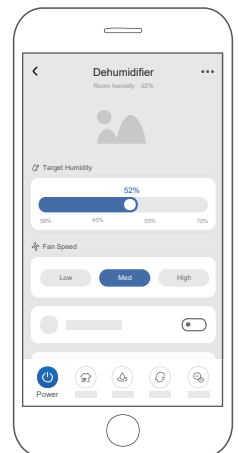
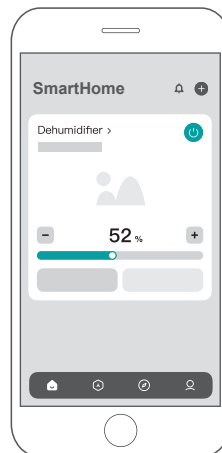

Compliance

We, hereby declare that this dehumidifier is in compliance with the relevant provisions of RE Directive 2014/53/EU. A copy of the full DoC is attached (European Union products only).

Wireless module models:

US-SK105:

FCC ID: 2ADQOMDNA21

IC: 12575A-MDNA21

This device complies with Part 15 of the FCC Rules and it contains licence exempt transmitter(s) / receiver(s) that comply with Innovation, Science and Economic Development Canada's licence-exempt RSS(s).

Operation is subject to the following two conditions:

- (1) This device may not cause harmful interference;
- (2) This device must accept any interference, including interference that may cause undesired operation of the device.

Only operate the device in accordance with the instructions supplied.

Changes or modifications to this unit not expressly approved by the party responsible for compliance could void the user's authority to operate the equipment.

This device complies with FCC radiation exposure limits set forth for an uncontrolled environment. In order to avoid the possibility of exceeding the FCC radio frequency exposure limits, human proximity to the antenna shall not be less than 20cm (8 in) during normal operation.

NOTE

This equipment has been tested and found to comply with the limits for a Class B digital device, pursuant to part 15 of the FCC Rules. These limits are designed to provide reasonable protection against harmful interference in a residential installation. This equipment generates, uses and can radiate radio frequency energy and, if not installed and used in accordance with the instructions, may cause harmful interference to radio communications. However, there is no guarantee that interference will not occur in a particular installation. If this equipment does cause harmful interference to radio or television reception, which can be determined by turning the equipment off and on, the user is encouraged to try to correct the interference by one or more of the following measures:

- Reorient or relocate the receiving antenna.
- Connect the equipment into an outlet on a circuit different from that to which the receiver is connected.
- Consult the dealer or an experienced radio/TV technician for help.

CLEANING AND MAINTENANCE

Turn the dehumidifier off and disconnect the plug from the power source before cleaning.

1. Clean the Grill and Case

- Use water and a mild detergent. Do not use bleach or abrasives.
- Do not splash water directly onto the unit. Doing so may cause an electrical shock, cause the insulation to deteriorate, or cause the unit to rust.
- The air intake and outlet may get dirty during operation, use a vacuum cleaner or brush to clean.

2. Clean the Bucket

- Every few weeks, clean the bucket thoroughly to prevent growth of mold, mildew and bacteria. Partially fill the bucket with clean water and mild detergent. Swish it around in the bucket, empty and rinse.

NOTE

Do not use a dishwasher to clean the bucket.

3. Clean the Air Filter

- To remove the filter, pull each filter outwards (See Fig. 19).
- Wash the filter with clean water then dry.
- Re-install each filter.
- Reset the filter indicator light following operating instructions on page 16.

4. Clean the Pump Filter (*pump models only*)

- To clean the pump filter, turn off and unplug the unit. Remove it from the bucket. Set it on a flat surface away from any electrical components. You can set the unit near a sink to easily rinse the filter.
- Rinse the pump filter with clean water to remove any dust or debris that may have collected on the mesh screen inside. Instead of rinsing, you can also clean the filter and screen with a soft brush or sponge.

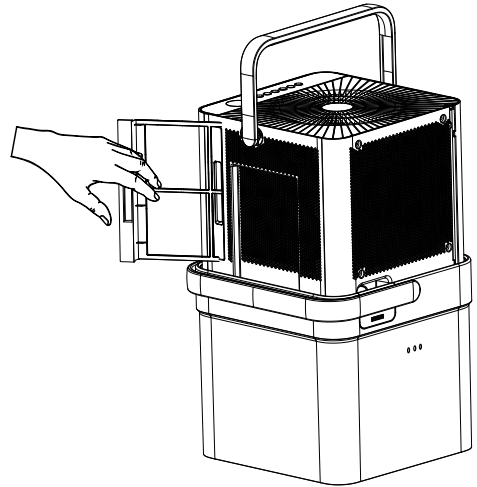

Fig. 19

CAUTION

To avoid loss of performance or damage to the unit, do not operate the dehumidifier without the filters.

5. When Not Using the Unit for Long Time Periods

- Before storing the unit and bucket, let it rest for one full day so that the system can dry out naturally.
- Clean the unit, water bucket and air filter.
- Ensure the power cord is in the power cord storage channel.
- Nest the unit inside the bucket.
- Cover the unit with a plastic bag.
- Store the unit upright in a dry, well-ventilated area.

Nesting and Storing Instructions

Step 1:

Power off and unplug the unit. Then lift the dehumidifier off the bucket.

Step 2:

Empty all water from bucket.

WARNING

Make sure the bucket is empty before nesting the dehumidifier to avoid risk of electrical shock.

Step 3:

Make sure to press the tabs on the inside bucket feature in so that the unit can nest correctly. See Fig. 21.

Step 4:

Rotate dehumidifier 90° in either direction and insert into bucket to nest.

NOTE

Make sure the power cord is properly tucked into the power cord storage channel on the back of the dehumidifier to prevent damage.

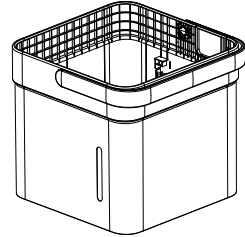
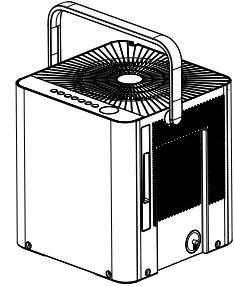

Fig. 20

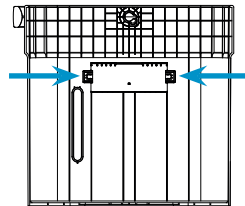

Fig. 21

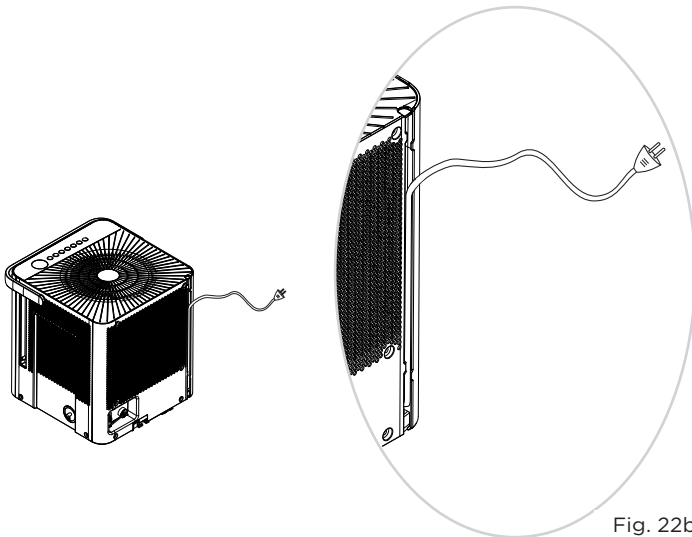

Fig. 22b

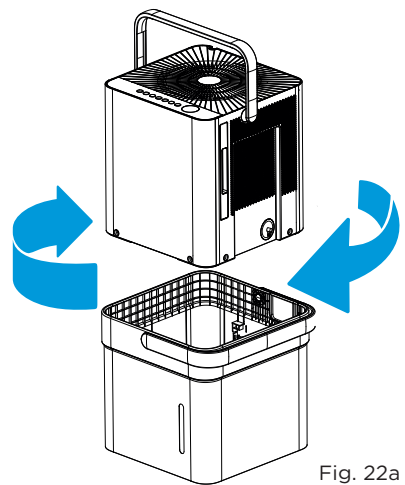

Fig. 22a

Step 5:

The dehumidifier is nested and ready to store.

CAUTION

When carrying the nested unit, be sure and use the bucket handle to ensure both the dehumidifier and bucket are safely carried.

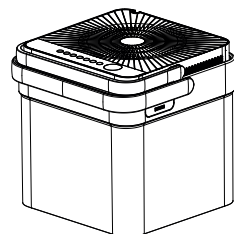

Fig. 23

TROUBLESHOOTING TIPS

Malfunction Diagnosis

Before calling for service, review this list. It may save you time and expense. This list includes common occurrences that are not the result of defective workmanship or materials in this appliance.

Problem	Solution
Unit does not start	Make sure the dehumidifier plug is connected firmly into the wall outlet.
	Check the house fuse/circuit breaker box.
	Dehumidifier has reached its preset level or bucket is full.
	Water bucket is not in the proper position.
Dehumidifier does not dry the air as it should	Not enough time to remove the moisture.
	Make sure there are no curtains, blinds or furniture blocking the front or back of the dehumidifier.
	The humidity control may not be set low enough.
	Check that all doors, windows and other openings are securely closed.
	Room temperature is too low, below 5°C (41°F).
The unit makes a loud noise when operating	There is a water vapor source in the room.
	Air filter may be dirty. Clean filter. Refer to Care and Cleaning section.
	The unit is tilted instead of upright as it should be.
Frost appears on the coils	The floor surface is not level.
	This is normal. The dehumidifier has Auto defrost feature.
Water on floor	Hose to connector or hose connection may be loose.
	Intended to use the bucket to collect water, but the back drain plug is removed.
ES, AS, P2, EC, Eb and E3 appear in the display	These are error codes and protection code. Check Operating Instructions.
The pump operation on light blinks at 1 Hz	Clean the pump filter.
	Check the pump hose is not blocked or leaking.
	Empty the water bucket.
When operating in bucketless mode, water collects around the bottom of the unit	Check to ensure the unit is level, and there is no debris on the surface.
	Check the drain hose connection and ensure it is properly seated in the outlet.
Unit will not connect to Wireless or App does not work.	For additional support and troubleshooting tips, visit the "Help" tab within the SmartHome app.

WARRANTY

Air Conditioner Limited Warranty

Your product is protected by this Limited Warranty:

Warranty service must be obtained from Midea Consumer Services or an authorized Midea servicer.

Warranty

- One Year Full Warranty from original purchase date.

Midea, through its authorized servicers will:

- Pay all costs for repairing or replacing parts of this appliance which prove to be defective in materials or workmanship.

Consumer will be responsible for:

- Diagnostics, removal, transportation and reinstallation cost required because of service.
- Costs of service calls that are a result of items listed under NORMAL RESPONSABILITIES OF THE CONSUMER**

Midea replacement parts shall be used and will be warranted only for the original warranty.

NORMAL RESPONSABILITIES OF THE CONSUMER**

This warranty applies only to products in ordinary household use, and the consumer is responsible for the items listed below:

1. Proper use of the appliance in accordance with instructions provided with the product.
2. Routine maintenance and cleaning necessary to keep the good working condition.
3. Proper installation by an authorized service professional in accordance with instructions provided with the appliance and in accordance with all local plumbing, electrical and/or gas codes.
4. Proper connection to a grounded power supply of sufficient voltage, replacement of blown fuses, repair of loose connections or defects in house wiring.
5. Expenses for making the appliance accessible for servicing.
6. Damages to finish after installation.

EXCLUSIONS

This warranty does not cover the following:

- 1) Failure caused by damage to the unit while in your possession (other than damage caused by defect or malfunction), by its improper installation, or by unreasonable use of the unit, including without limitation, failure to provide reasonable and necessary maintenance or to follow the written Installation and Operating Instructions.
- 2) Damages caused by service performed by persons other than those authorized by Midea customer service; or external causes such as abuse, misuse, inadequate power supply or acts of God.
- 3) If the unit is put to commercial, business, rental, or other use or application other than for consumer use, we make no warranties, express or implied, including but not limited to, any implied warranty of merchantability or fitness for use or purpose.
- 4) Products without original serial numbers or products that have serial numbers which have been altered or cannot be readily determined.

NOTICE: Some states do not allow the exclusions or limitation of incidental or consequential damages. So this limitation or exclusion may not apply to you.

IF YOU NEED SERVICE

Keep your bill of sale, delivery slip, or some other appropriate payment Record.

The date on the bill establishes the warranty period, should service be required.

If service is performed, it's your best interest to obtain and keep all receipts.

This written warranty gives you specific legal rights. You may also have other rights that vary from state to state.

Service under this warranty must be obtained by following these steps, in order:

- 1) Contact Midea Consumer Services or an authorized Midea services at 1 866 646 4332.
- 2) If there is a question as to where to obtain service, contact our consumer relations Department.



make yourself at home



www.midea.com

© Midea 2023 all rights reserved

CD001UI-DM(NEW)A

16120100A19855

20231215