

Dehumidifier
MAD



SmartHome

Download the app
& activate product



USER MANUAL

MAD22S1AWWT
MAD35S1AWWT
MAD50PS1AWBL

Warning notices: Before using this product, please read this manual carefully and keep it for future reference. The design and specifications are subject to change without prior notice for product improvement. Consult with your dealer or manufacturer for details. The diagram above is just for reference. Please take the appearance of the actual product as the standard.

THANK YOU LETTER

Thank you for choosing Midea! Before using your new Midea product, please read this manual thoroughly to ensure that you know how to operate the features and functions that your new dehumidifier offers in a safe way.

CONTENTS

THANK YOU LETTER	2
SAFETY INSTRUCTIONS	3
GET TO KNOW YOUR PRODUCT	7
PRODUCT INSTALLATION	8
GET TO KNOW YOUR FEATURES	11
REMOVING COLLECTED WATER	15
APP INSTRUCTIONS	18
CLEANING AND MAINTENANCE	22
TROUBLESHOOTING TIPS	24
WARRANTY	25
RETURN POLICY	26

Read This Manual

Inside you'll find many helpful hints on how to use and maintain your dehumidifier properly. Just a little preventive care on your part can save you a great deal of time and money over the life of your appliance. You'll find many answers to common problems in the troubleshooting tips - you should be able to fix most of them quickly before calling service. These instructions may not cover every possible condition of use, so common sense and attention to safety is required when installing, operating and maintaining this product.



CAUTION

- For support, please call the Service Center at 1-866-646-4332.
- This appliance is not intended for use by people (including children) with reduced physical, sensory, or mental capabilities or lack of experience and knowledge, unless they have been given supervision or instruction concerning use of the appliance by a person responsible for their safety.
- Children should be supervised to ensure that they do not play with the appliance.
- The appliance shall be installed in accordance with national wiring regulations.

SAFETY PRECAUTIONS

Must read the warning message

Read Safety Precautions Before Operation and Installation. To prevent injury to the user or personal and property damage, these instructions must be followed. Incorrect operation due to ignoring of instructions may cause harm or damage. The level of risk is shown by the following indications.

Explanation of Symbols



WARNING

The signal word indicates a hazard with a medium level of risk which, if not avoided, may result in death or serious injury.



CAUTION

The signal word indicates a hazard with a low degree of risk which, if not avoided, may result in minor or moderate injury.

WARNING

Please read through these instructions before you start the installation process. Improper installation can cause damage to the unit and/or personal property and can be a personal safety hazard.

- Do not exceed the rating of the power outlet or connection device.
- Do not operate or stop the unit by switching on or off the power.
- Do not damage or use an unspecified power cord.
- Do not modify power cord length or share the outlet with other appliances.
- Do not insert or pull out plug with wet hands.
- Do not install the appliance in a location that may be exposed to combustible gas.
- Do not place the unit near a heat source.
- Disconnect the power if strange sounds, smell, or smoke comes from it.
- Never try to take apart or repair the unit by yourself.
- Before cleaning, turn off the power and unplug the unit.
- Do not use the machine near flammable gas or combustibles, such as gasoline, benzene, thinner, etc.
- Do not drink or use the water drained from the unit.
- Do not take the side access tank out during operation.
- Do not use the unit in small spaces.
- Do not put in places where water may splash onto the unit.
- Place the unit on a level, sturdy section of the floor.
- Do not cover the intake or exhaust openings with cloths or towels.
- Care should be taken when using the unit in a room with the following persons: infants, children, elderly people, and people with reduced physical, sensory, or mental capabilities.
- Do not use in areas where chemicals are handled.
- Never insert your finger or other foreign objects into grills or openings. Take special care to warn children of these dangers.
- Do not place heavy objects on the power cord and take care so that the cord is not compressed.
- Do not climb up on or sit on the unit.
- Always insert the filters securely. Clean filter once every two weeks.
- If water enters the unit, turn the unit off and disconnect the power, contact a qualified service technician.
- Do not place flower vases or other water container filled s on top of the unit.
- Do not use extension cords.

CAUTION

- This appliance is not intended for use by persons (including children) with reduced physical, sensory or mental capabilities or lack of experience and knowledge, unless they have been given supervision or instruction concerning use of the appliance by a person responsible for their safety.
- Children should be supervised to ensure that they do not play with the appliance.
- If the supply cord is damaged, it must be replaced by the manufacturer, its service agent or similarly qualified persons in order to avoid a hazard.
- Prior to cleaning or other maintenance, the appliance must be disconnected from the power supply.
- Do not install the appliance in a location that may be exposed to combustible gas.
- If combustible gas accumulates around the unit, it may cause fire.
- If the appliance is knocked over during use, turn off the unit and unplug it from the main power supply immediately. Visually inspect the unit to ensure there is no damage. If you suspect the unit has been damaged, contact a technician or customer service for assistance.
- Our product should not be used in a water damaged environment.
- In a thunderstorm, the power must be cut off to avoid damage to the machine due to lightning.
- Do not run cord under carpeting. Do not cover cord with throw rugs, runners, or similar coverings. Do not route cord under furniture or appliances. Arrange cord away from traffic area and where it will not be tripped over.
- Do not operate unit with a damaged cord or plug. Discard unit or return to an authorized service facility for examination and/or repair.
- The appliance shall be installed in accordance with national wiring regulations.
- Contact the authorized service technician for repair or maintenance of this unit.
- Turn off the product when not in use.
- The manufacturer's nameplate is located on the panel of the unit and contains electrical and other technical data specific to this unit.
- Be sure the unit is properly grounded. To minimize shock and fire hazards, proper grounding is important.
- The power cord is equipped with a three-prong grounding plug for protection against shock hazards.
- Your unit must be used in a properly grounded wall receptacle. If the wall receptacle you intend to use is not adequately grounded or protected by a time delay fuse or circuit breaker (please refer to the nameplate for the electrical data), have a qualified electrician install the proper receptacle.
- The unit's circuit board (PCB) is designed with a fuse to provide overcurrent protection. Specifications of the fuse are printed on the circuit board, such as: T 3.15A/250V (or 350V), etc.

Electronic Work

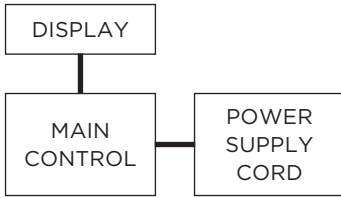

NOTE

The cognographs are for explanation purpose only. Your machine may be slightly different. The actual shape shall prevail.

WARNING

BEFORE PERFORMING ANY ELECTRICAL OR WIRING WORK, TURN OFF THE MAIN POWER TO THE SYSTEM.



CAUTION:
Risk of fire
flammable materials

IMPORTANT NOTE: Read this manual carefully before installing or operating your new appliance unit. Make sure to save this manual for future reference.

Explanation of symbols displayed on the unit

	CAUTION	This symbol shows that the operation manual should be read carefully.
	CAUTION	This symbol shows that a service personnel should be handling this equipment with reference to the installation manual.
	CAUTION	This symbol shows that information is available such as the operating manual or installation manual.

WARNING

- Servicing shall only be performed as recommended by the equipment manufacturer. Maintenance and repair requiring the assistance of other skilled personnel shall be carried out under the supervision of a person competent in the use of flammable refrigerants.
- DO NOT modify the length of the power cord or use an extension cord to power the unit.
- DO NOT share a single outlet with other electrical appliances. Improper power supply can cause fire or electrical shock. Please follow the instructions carefully to handle, install, clean, and service the appliance to avoid any damage or hazard.

WARNING (for using R32 refrigerant)

Flammable!

Refrigerant R32 is used within appliance.

- When maintaining or disposing the appliance, the refrigerant (R32) shall be recovered properly, shall not discharge to air directly.
- Compliance with national gas regulations shall be observed.
- Keep ventilation openings clear of obstruction.
- The appliance shall be stored so as to prevent mechanical damage from occurring.
- A warning that the appliance shall be stored in a well-ventilated area where the room size corresponds to the room area as specified for operation.
- Any person who is involved with working on or breaking into a refrigerant circuit should hold a current valid certificate from an industry-accredited assessment authority, which authorizes their competence to handle refrigerants safely in accordance with an industry recognized assessment specification.

Examples for such working procedures are:

- Breaking into the refrigerating circuit;
- Opening of sealed components;
- Opening of ventilated enclosures.
- No any open fire or device like switch which may generate spark/arc shall be around appliance to avoid causing ignition of the flammable refrigerant used. Please follow the instruction carefully to store or maintain the appliance to prevent mechanical damage from occurring.
- Do not use means to accelerate the defrosting process or to clean, other than those recommended by the manufacturer.
- The appliance shall be stored in a room without continuously operating ignition sources (for example: open flames, an operating gas appliance) and ignition sources (for example: an operating electric heater) close to the appliance.
- Do not pierce or burn.
- Be aware that the refrigerants may not contain an odor.

GET TO KNOW YOUR PRODUCT

Identification of Parts

Name of each component of the product

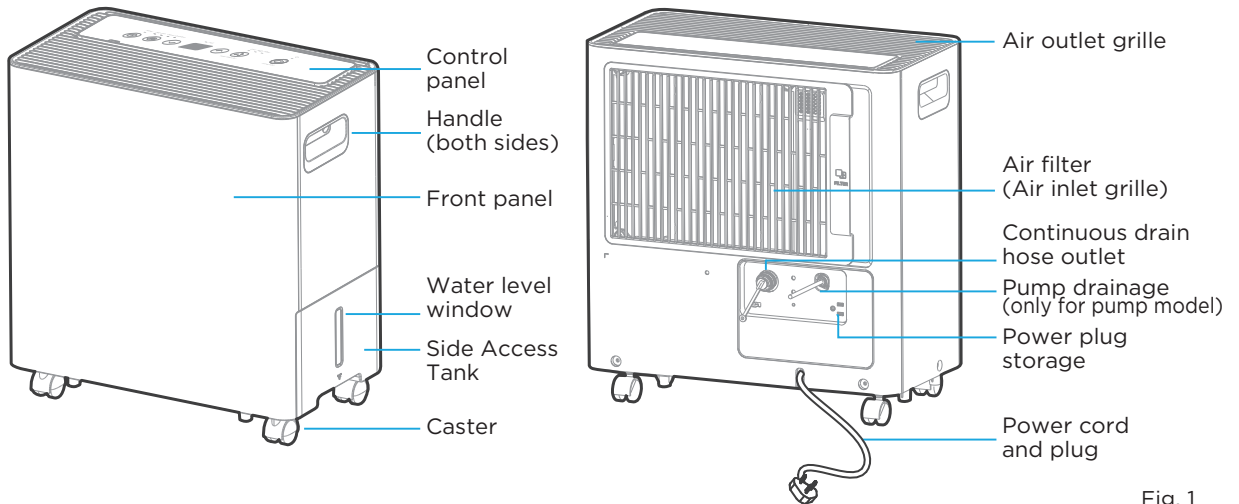

Fig. 1

NOTE

All the illustrations in the manual are for explanation purpose only. Your machine may be slightly different. The actual shape shall prevail. The unit can be controlled by the unit control panel.

Accessories

Caster (4 pc)

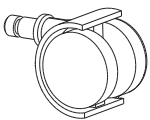

Cushion pad (1 pc)

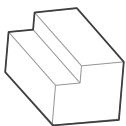

Optional accessories

Pump drain hose *1 pc (For the unit with pump feature)

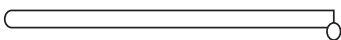

PRODUCT INSTALLATION

Positioning the Unit

Safe distance requirements

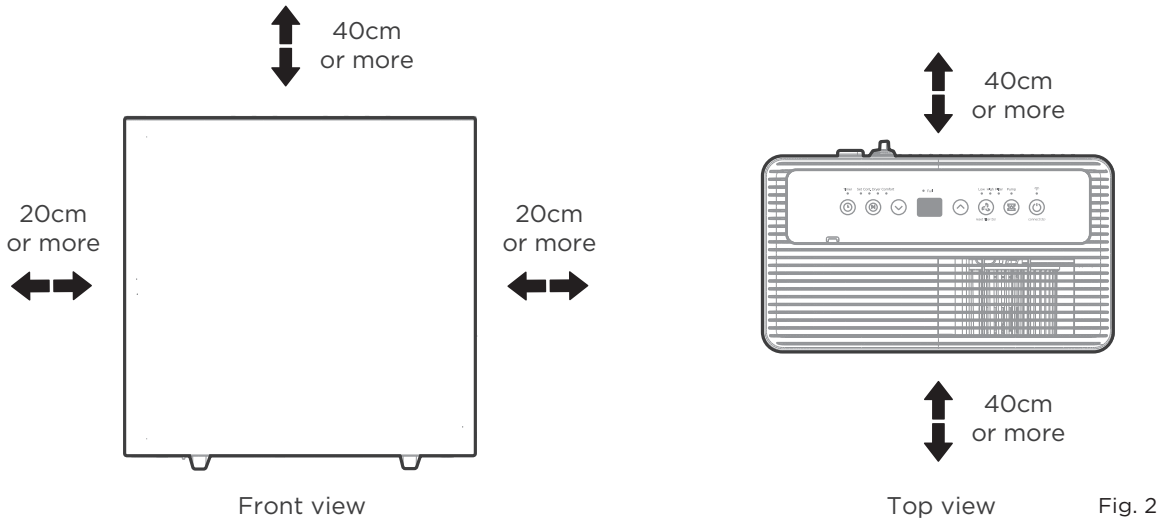

NOTE

Casters (At four points on the bottom of unit)

- Casters can move freely.
- Do not force casters to move over carpet.
- Do not move the unit with water in the bucket. (The unit may tip over and spill water.)

A dehumidifier operating in a basement will have little or no effect in drying an adjacent enclosed storage area, such as a closet, unless there is adequate circulation of air in and out of the area. (See Fig. 2)

- Do not use outdoors.
- This dehumidifier is intended for indoor residential applications only.
- This dehumidifier should not be used for commercial or industrial applications.
- Place the dehumidifier on a smooth, level floor strong enough to support the unit with a full bucket of water.
- Allow at least 20cm of air space on all sides of the unit for good air circulation (at least 40cm of air space on air outlet).
- Place the unit in an area where the temperature will not fall below 41°F (5°C). The coils can become covered with frost at temperatures below 41°F (5°C), which may reduce performance.
- Place the unit away from the clothes dryer, heater or radiator.
- Use the unit to prevent moisture damage anywhere books or valuables are stored.
- Use the dehumidifier in a basement to help prevent moisture damage.
- The dehumidifier must be operated in an enclosed area to be most effective.
- Close all doors, windows and other outside openings to the room.
- Before tilting or moving the unit in any way, take out the bucket, open the continuous drain outlet to empty the water, and disconnect the power cord.

When Using Your Product

Preparations for product use

NOTE

When the water in the bucket reaches to a certain level, please be careful to move the machine to avoid it tipping over.

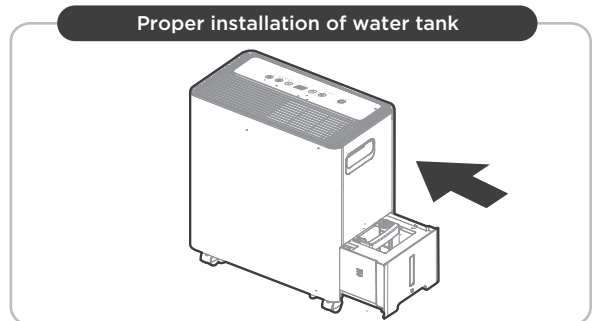
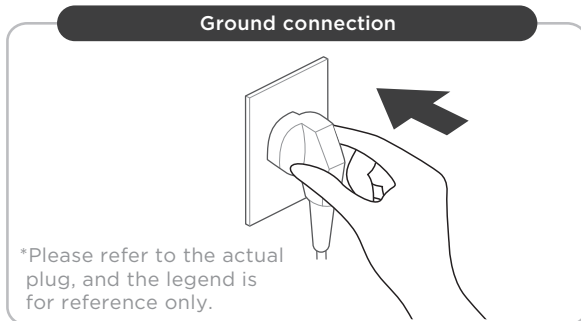
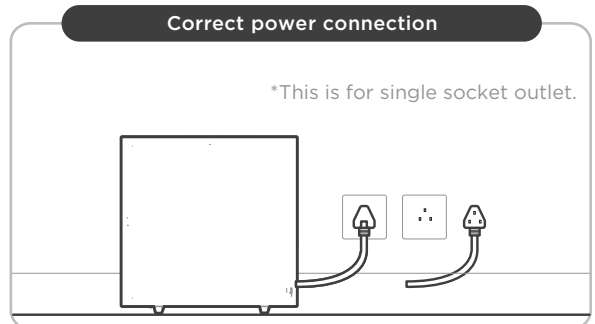
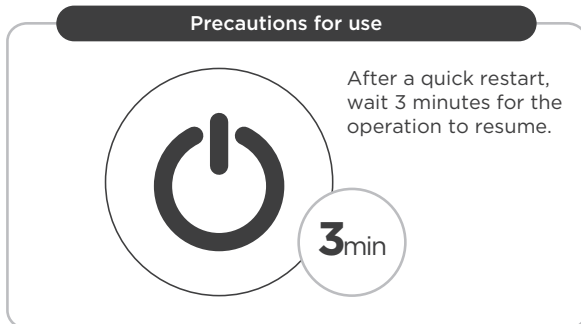
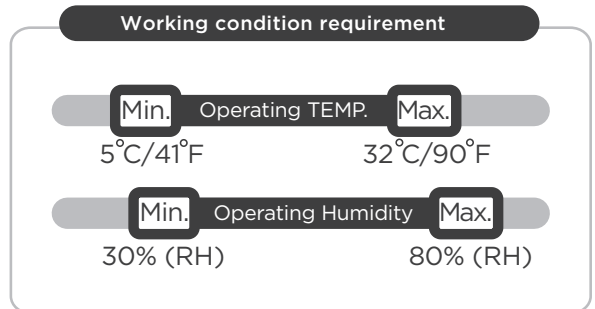
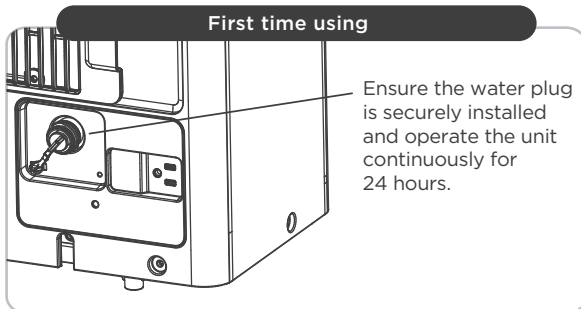

- When first using the dehumidifier, operate the unit continuously for 24 hours. Ensure that the plastic cover is securely installed in continuous dehumidification mode and does not leak.
- This unit is designed to operate with a working environment between 5°C/41°F and 32°C/90°F, and between 30% (RH) and 80% (RH).
- When use in open space with open windows, condensation may form on the surface of the product, which is normal.
- If the unit has been switched off and needs to be switched on again quickly, allow approximately three minutes for the correct operation to resume.
- Do not connect the dehumidifier to a multiple socket outlet, which is also being used for other electrical appliances.
- Select a suitable location, making sure you have easy access to an electrical outlet.
- Plug the unit into an electrical socket-outlet with ground connection.
- Make sure the side access tank is correctly fitted otherwise the unit will not operate properly.

Caster Installation

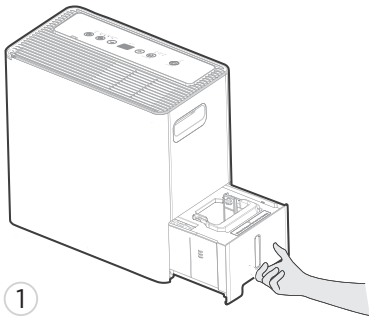

① Pull out the side access tank.

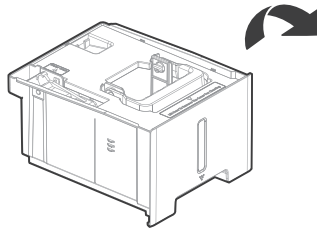

② Take out a cushion pad and four casters from the bucket, then reinstall the side access tank.

Cushion pad (1 pc)

Caster (4 pc)

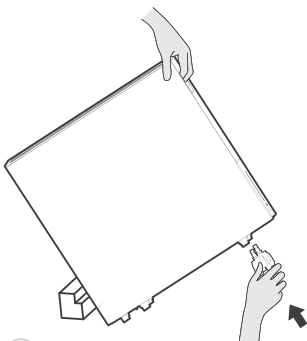

③ Tilt the unit on its side and hold it with one hand, then insert two casters.

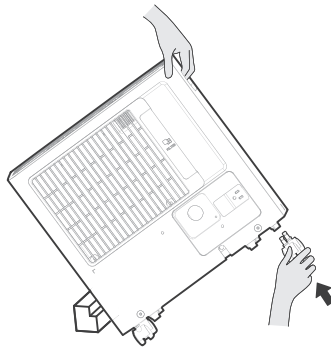

Rotate the unit and hold it with one hand, then insert the other two casters.



Before inserting

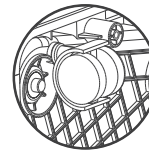

Correctly inserted

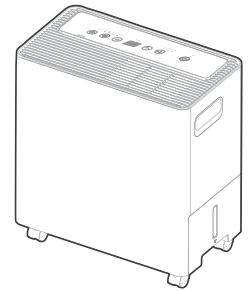

④ Leave the unit standing up for half an hour before use.

⚠ WARNING

- Take out the bucket, drain the water outlet and reinstall the plastic cover before installing casters.
- The tilt angle is not to exceed 30 degrees when installing casters, and all casters **MUST BE** installed within 5 minutes.
- After the caster installation is complete, set the unit upright and rest for 30 minutes before starting the unit.

Step 1

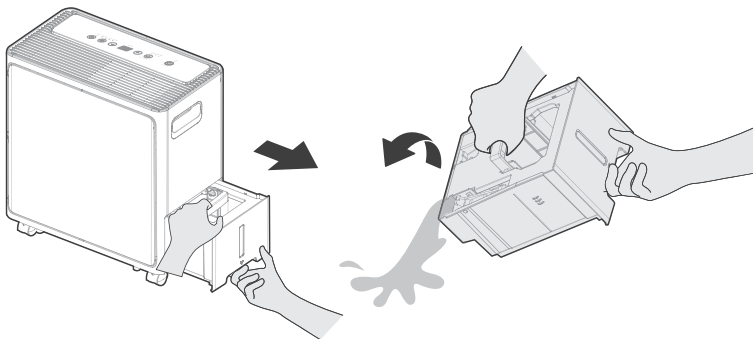

Step 2

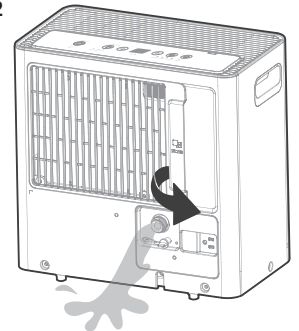

Fig. 3

Fig. 4

GET TO KNOW YOUR FEATURES





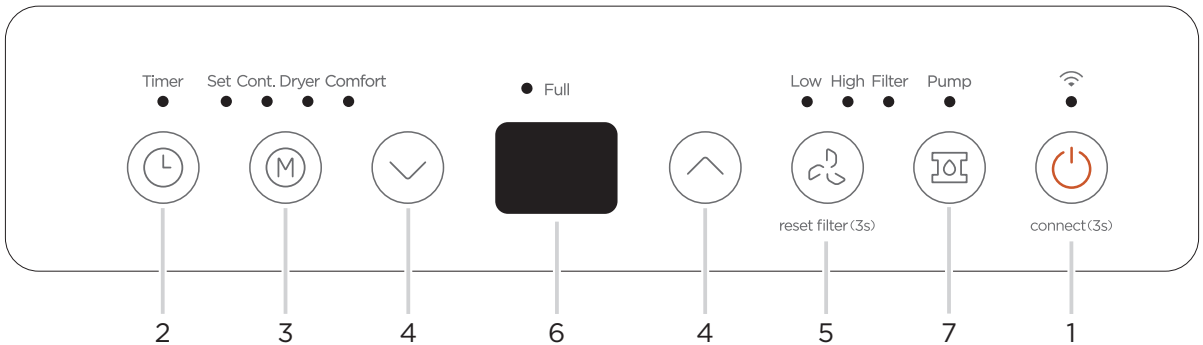

Control Panel Features

Operation Display

NOTE

The following control panels are for explanation purpose only. The control panel of the unit you purchased may be slightly different according to the models. Your machine may not contain some indicators or buttons. The actual shape will remain the same.



		Description
1	 connect(3s)	ON / OFF <ul style="list-style-type: none"> Press to turn unit on or off. Press for 3 sec to initiate wireless connection mode.
2		TIMER Button <ul style="list-style-type: none"> Press to turn unit Auto Start/Stop.
3		Mode Button <ul style="list-style-type: none"> Press to choose operating mode in a sequence: Set → Cont. → Dryer → Comfort
4		UP / DOWN Buttons <ul style="list-style-type: none"> Press to set humidity and timer.
5	 reset filter (3s)	FAN Button <ul style="list-style-type: none"> Press to select the Fan Speed in two steps: High and Low. Press to turn off the cleaning filter reminder.
6		LED Display <ul style="list-style-type: none"> Show the ambient humidity and set humidity, set time (when timer function is used), and the error codes.
7		PUMP Button (only for pump model) <ul style="list-style-type: none"> Press to activate the built-in pump function.

1. POWER ON/OFF Button:

Press to turn the dehumidifier on and off.

WIRELESS Button

1. Press and hold on the POWER button for 3 seconds to initiate the Wireless connection mode. The LED DISPLAY shows 'AP' to indicate you can set Wireless connection.
2. If connection (router) is successful within 8 minutes, the unit will exit Wireless connection mode automatically and the Wireless indicator illuminates and the unit enters the previous function. If connection fails within 8 minutes, the unit exits the Wireless connection mode automatically.

NOTE

When the unit is connecting to the internet, the quick glance light will flash white light.

2. TIMER Function:

Press the Timer button to initiate the Auto start and Auto stop function, in conjunction with the UP and DOWN buttons.

Auto start setting

1. In the shutdown state, press the Timer button to active the Auto start time.
2. Press or hold the UP or DOWN button to change the Auto start time by 0.5 hour increments, up to 10 hours, then at 1 hour increments, up to 24 hours.
3. The selected time will register in 5 seconds and the system will automatically revert. The control will count down the time remaining until start.

Auto stop setting

1. In the startup state, press the Timer button to active the Auto stop time.
2. Press or hold the UP or DOWN button to change the Auto stop time by 0.5 hour increments, up to 10 hours, then at 1 hour increments, up to 24 hours.
3. The selected time will register in 5 seconds and the system will automatically revert. The control will count down the remaining time until stop.

NOTE

The timing can be adjusted to increase or decrease by 24 hours. After the TIMER setting is complete, you can press the button again to check the TIMER setting status. After the TIMER setting is complete, you can cancel it by setting the set time to 0.0.

3. MODE Function:

Press the button to select the mode you want, as shown: Set → Cont. → Dryer → Comfort.

NOTE

Dryer and Comfort are optional; The humidity setting cannot be manually adjusted in Dryer, Cont. and Comfort Mode; The set humidity will be displayed when the selected mode is Set, and the ambient humidity will be displayed 5 seconds later.

Set Dehumidifying mode (Set)

Set mode allows you to manually adjust the desired humidity level between 35% and 85%.

Press the button to select the Dehumidifying mode, and adjust the desired humidity by pressing the UP and DOWN buttons.

NOTE

Humidity can be set from 35% to 85%, with 5% adjustment per press.

Continuous Dehumidifying Mode (Cont.)

In Continuous mode, the dehumidifier works continuously to remove moisture from the air.

Press the button to select the Continuous dehumidifying mode.

NOTE

Humidity cannot be adjusted in this mode.

Comfort Dehumidifying Mode - optional

In Comfort dehumidifying mode, the unit will automatically control room humidity in a comfortable range from 45%-55% according to the room temperature.

Press the button to select the Comfort dehumidifying mode.

NOTE

Humidity cannot be adjusted in this mode.

Dryer mode (Dryer) - optional

In dryer mode, the unit will filter out moisture and blow it back into the room at a warmer temperature on a higher fan setting.

Press the button to select the Dryer mode, and the unit will operate in Continuous dehumidifying and High fan speed mode, in this mode.

NOTE

For some models, The unit will quit Dryer mode after a maximum 10 hours operation.

1. Close doors and Windows while operating in this mode.
2. For best results, please ring out excess moisture from the clothes before using the dryer mode.
3. Make sure to direct airflow at the wet clothes.
4. Clothes that are thick and heavy may not dry as effectively.

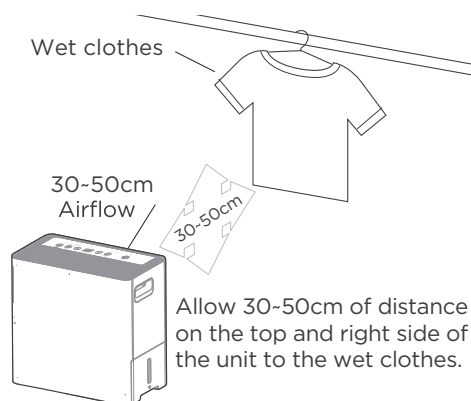

Fig. 5

4. UP AND DOWN Buttons:

Humidity Set Control Buttons

The humidity level can be set within a range of 35% RH (Relative Humidity) to 85% RH (Relative Humidity) in 5% increments.

TIMER Set Control Buttons

Press the UP and DOWN buttons to set the Auto start and Auto stop time from 00:00 to 24:00.

5. FAN SPEED Function:

Press the button to select fan speed in the following setting: Low → High → Low ...

NOTE

The fan speed indicator light illuminates under different fan speed settings.

6. DISPLAY:

The electronic display will show the ambient humidity and set humidity. When the timer function is used, the display will show the set time. If there is an error, the display will show the error code.

Error Codes:

ES/EH61 - Evaporator coil temperature sensor error. Unplug the unit and plug it back in. If the error repeats, call for service.

AS/EH60 - Room temperature sensor error. Unplug the unit and plug it back in. If the error repeats, call for service.
P2 - Bucket is full of water or bucket is not in right position. Empty the bucket and replace it in the right position.

P1 - Unit is defrosting. Allow the unit time to automatically service. The protection will clear after the unit self defrosts. (some units)

EH00 - Indoor EEPROM error. Unplug the unit and plug it back in. If error repeats, call for service. (some units)

7. PUMP Function (only for pump model):

Press the  button to activate the built-in pump function. Pump Mode Indicator will be on. When using this function, the unit will automatically pump water out until the water tank is empty. The pump will stop automatically once the water tank is empty.

NOTES

- Pump drain hose must be well connected for this mode.
- Make sure the drain hose is pointed in the direction where you would like to drain the water to.
- If the pump indicator light and bucket full indicator light flash simultaneously after pressing the Pump button, the drain hose may not be installed correctly. See page 16 for instructions on how to properly install the drain hose.

More Features

AUTO SHUT OFF

The dehumidifier shuts off when the bucket is full, or when the bucket is removed or not replaced in the proper position. For some models, the fan motor will continue to run for 30 seconds.

When the Full indicator light illuminates, please empty the bucket and reinstall it correctly.

Then, wait 3 minutes before resuming operation, it cannot restart operation in the first 3 minutes. This is to protect the unit.

Operation will automatically start after 3 minutes.

CHECK FILTER FEATURE

The unit will automatically track how long the fan motor has been in use. Once the accumulated operation time reaches 250 hours, the check filter light will turn on, letting you know it is the optimal time to clean the filter. After cleaning and reinserting the filter, press and hold the FAN (reset filter) button for 3 seconds to turn the light off. This will repeat after every 250 hours of use.

AUTO-RESTART

If the unit turns off unexpectedly due to loss of power, it will restart with the previous function setting automatically when the power resumes.

REMOVING COLLECTED WATER

When Your Bucket Is Full

There are different ways to remove collected water.

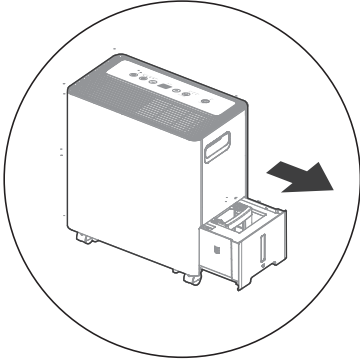

Type 1:

Bucket drainage

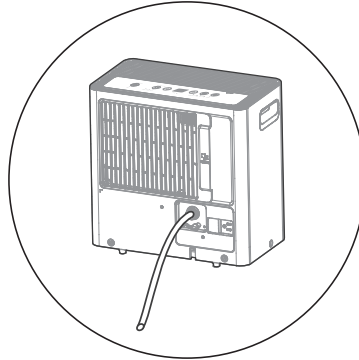

Type 2:

Water hose drainage
(continuous)

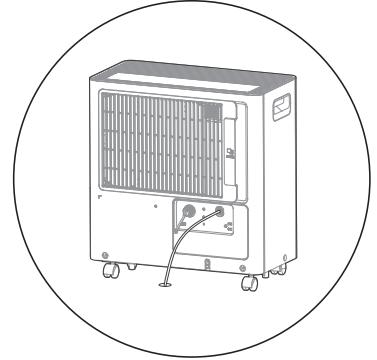

Type 3:

Pump drainage
(only for pump model)

Type 1: Bucket drainage

- When the unit is off, if the bucket is full, the Full indicator light will turn on.
- When the unit is on, if the bucket is full, the compressor and the fan turn off, and the Full indicator light will turn on, the digital display shows P2.
- Pull the bucket out halfway, then pull up the handle and lift the bucket slowly vertically to prevent spillage.
- Dump the water and replace the bucket. The bucket must be correctly installed for the dehumidifier to operate.
- The appliance will re-start when the bucket is restored in its correct position.

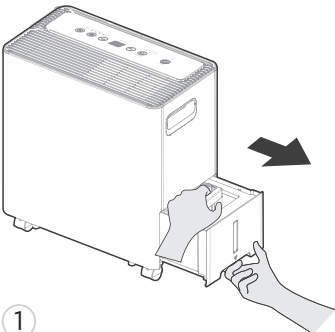

1

Pull the bucket out halfway.

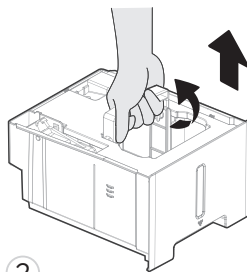

2

Pull up the handle and lift
the bucket slowly vertically.

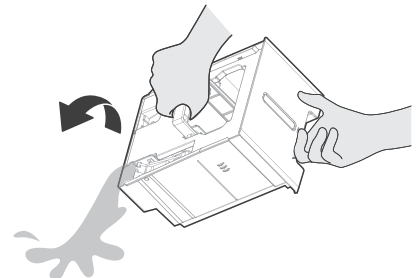

3

Pour the water out.

⚠ WARNING

Do not pull out the whole bucket without grabbing the handle, or it may cause damage to the bucket or even injure you.

NOTE

- When you remove the bucket, do not touch any parts inside of the unit. Doing so may damage the product. Be sure to push the bucket gently all the way into the unit. Banging the bucket against anything or failing to push it in securely may cause the unit not to operate.
- If the pump hose becomes disconnected when you remove the bucket, you must reinstall the pump hose properly to the unit before replacing the bucket .
- When you remove the bucket, if there is some water in the unit you must dry it.
- When the unit is on, if the bucket is removed, the compressor and the fan turn off, then the unit will beep 8 times and the digital display shows Eb.
- When the unit is off, if the bucket is removed, the unit will beep 8 times and the digital display shows Eb.

Type 2: Water Hose Drainage (continuous)

Water can be automatically emptied into a floor drain by attaching the unit with a water hose (ID $\geq \text{Ø } 5/16''$, not included) with a female threaded end (ID: M=1", not included).

Before the water tank begins filling, remove the water plug from the drain outlet and set aside. Then, insert the drain hose through the water drain outlet. Lead the drain hose to the floor drain or a suitable drainage facility.

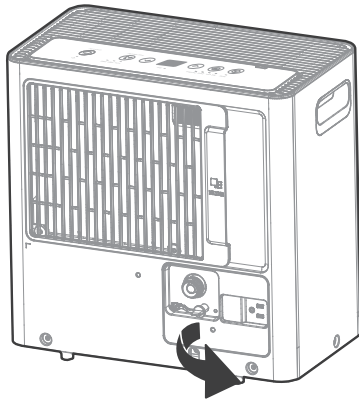

①
Remove the water plug.

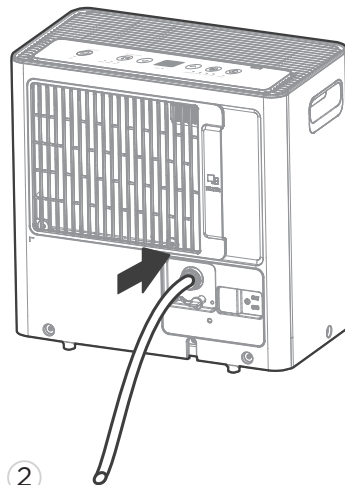

②
Connect the drain hose.

- When you remove the water plug, if there is any water in the back drain outlet of the unit you must dry it. Make sure the hose is secure so there are no leaks and the end of the hose is level or down to let the water flow smoothly.
- Direct the hose toward the drain, making sure that there are no kinks that will stop the watowing. Make sure the water hose is lower than the drain hose outlet of the unit.
- Select the desired humidity setting and fan speed on the unit for continuous draining to start.

NOTE

When the continuous draining feature is not being used, remove the drain hose from the outlet, and dry the water in the continuous drain hose outlet. After drying, make sure to reinstall the water plug.

Type 3: Pump Drainage (only for pump model)

To connect pump drain hose:

- Press the tightening ring of drainage joint (as shown as Fig. 6);
- Keep pressing the grey ring while pulling out the plug. (as shown as Fig. 7);
- Insert the drain hose onto the drainage joint, make sure it is connected well so that it is fully sealed.
- Place the other end of the drain hose in the location you want the water to go to, such as a floor drain, a water container, or through a basement window to the outdoors.

To remove pump drain hose:

- Press the tightening ring of drainage joint.
- Pull out the drain hose.
- Place the plug back to the joint.

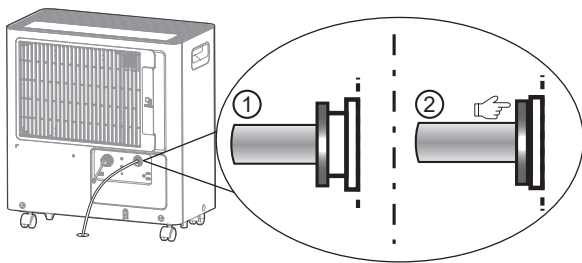

Fig. 6

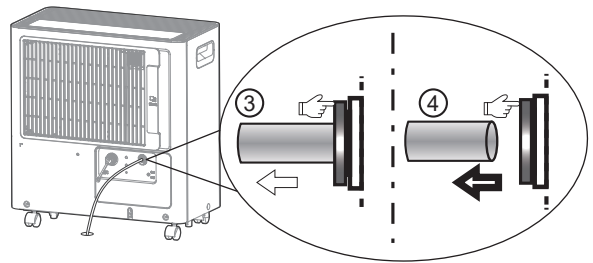

Fig. 7

NOTE

- The maximum distance and the rise may be 5m from the unit. Exceeding this distance may damage the unit or cause leaks.
- If removing the hose to use in Bucket mode, please reinsert the drain plug to prevent accidental water leakage. (You still need to press the tightening ring when removing the hose.)

APP INSTRUCTIONS

Specification of Wireless Module

Model: US-SK105	Dimensions: 41 x 24 x 5 (mm)
Antenna Type: Printed PCB Antenna	Operation Temperature: 0°C ~ 45°C / 32°F ~ 113°F
Frequency: WLAN 2400-2483.5 MHz	Operation Humidity: 10% ~ 85%
Maximum Transmitted Power: <20 dBm Max	Power Input: DC 5V/500 mA

Precautions

App Compatibility:

- The app is available for both iOS and Android, however older versions may no longer be compatible. Please keep the app updated with the latest version. Midea makes no guarantee of compatibility and is not responsible for issues arising as a consequence thereof.

Wireless Security:

- The Smart Kit supports the following security protocols: WPA-PSK / WPA2-PSK / WPA3-SAE.
- It may be used with or without encryption although encryption is strongly recommended.

Connectivity:

- Network issues may occasionally cause timeouts. The unit display and the app may become unsynchronized but this will resolve itself when the network is restored.
- Should the network remain unavailable, it might be necessary to run the configuration process again.
- Change in the wireless network will require reconfiguration of the device.

Configuration:

- The actual network configuration process may vary slightly from the manual.
- Please check the service website for more information.

NOTE

Midea will not be responsible for any problems that could be caused by incompatibility or network issues, your wireless router and mobile phone.

Using the SmartHome App

CAUTION

Ensure that your mobile phone is connected to the wireless network. Bluetooth must be turned on. The device must also be powered up.

Step 1: Download the SmartHome app

Scan the QR code below to download the SmartHome app from app store or search for it directly on the Google Play Store or Apple's App Store.



Step 2: Log in

Open the SmartHome app. Log in directly if you have an existing SmartHome account or create a new account. Alternatively, you can also use a 3rd party login platform.

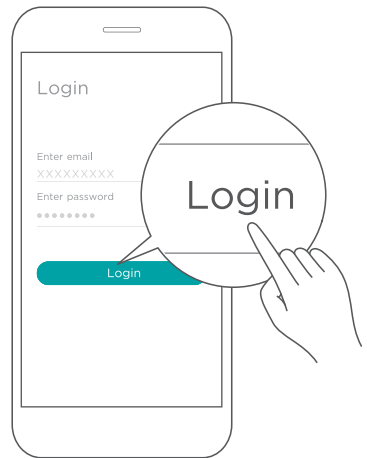

Step 3: Connecting the device

- 1) When you log in, you may see the message "Smart devices discovered nearby". Tap to add your device.

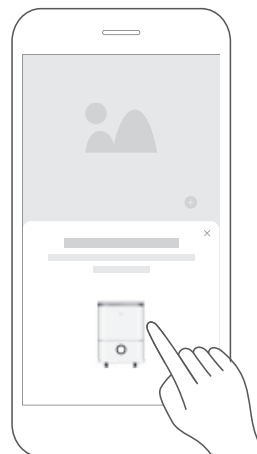

2) If no such message appears, proceed as follows:

Tap on “+” and select your device in the list of nearby available devices.

If your device is not listed, please add your device manually, first selecting the device category e.g. Dehumidifier.



3) Follow the steps in the app to connect your device to the wireless network. If your device fails to connect, follow the additional instructions in the app.



Step 4: Controlling the device

After pairing successfully, a card will be created for the device in the SmartHome app.

Shortcuts for basic functions will appear on the card such as changing the humidity or switching the device on or off.

Tapping on the card, will reveal additional features and settings.

The actual design may look different from examples due to app updates.

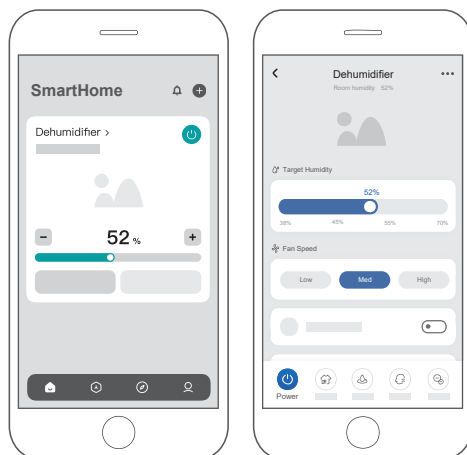

Compliance

We, hereby declare that this dehumidifier is in compliance with the relevant provisions of RE Directive 2014/53/EU.

Wireless module models:

US-SK105:

FCC ID: 2ADQOMDNA21

IC: 12575A-MDNA21

This device complies with Part 15 of the FCC Rules and it contains licence exempt transmitter(s) / receiver(s) that comply with Innovation, Science and Economic Development Canada's licence-exempt RSS(s).

Operation is subject to the following two conditions:

- (1) This device may not cause harmful interference;
- (2) This device must accept any interference, including interference that may cause undesired operation of the device.

Only operate the device in accordance with the instructions supplied.

Changes or modifications to this unit not expressly approved by the party responsible for compliance could void the user's authority to operate the equipment.

This device complies with FCC radiation exposure limits set forth for an uncontrolled environment. In order to avoid the possibility of exceeding the FCC radio frequency exposure limits, human proximity to the antenna shall not be less than 20cm (8 inches) during normal operation.

NOTE

This equipment has been tested and found to comply with the limits for a Class B digital device, pursuant to part 15 of the FCC Rules. These limits are designed to provide reasonable protection against harmful interference in a residential installation. This equipment generates, uses and can radiate radio frequency energy and, if not installed and used in accordance with the instructions, may cause harmful interference to radio communications. However, there is no guarantee that interference will not occur in a particular installation. If this equipment does cause harmful interference to radio or television reception, which can be determined by turning the equipment off and on, the user is encouraged to try to correct the interference by one or more of the following measures:

- Reorient or relocate the receiving antenna.
- Connect the equipment into an outlet on a circuit different from that to which the receiver is connected.
- Consult the dealer or an experienced radio/TV technician for help.

CLEANING AND MAINTENANCE

How To Clean & Care For Your Product

Turn the dehumidifier off and disconnect the plug from the power source before cleaning.

1. Clean the Grill and Case

- Use water and a mild detergent. Do not use bleach or abrasives.
- Do not splash water directly onto the unit. Doing so may cause an electrical shock, cause the insulation to deteriorate, or cause the unit to rust.
- The air intake and outlet grilles get soiled easily, so use a vacuum attachment or brush to clean.

2. Clean the bucket

Every few weeks, clean the bucket to prevent growth of mold, mildew and bacteria. Partially fill the bucket with clean water and add a little mild detergent. Swish it around in the bucket, empty and rinse.

NOTE

Do not use a dishwasher to clean the bucket. After cleaning, the bucket must be in place and securely seated for the dehumidifier to operate.

3. Clean the air filter

- To remove the filter every two weeks based on normal operating conditions.
- To remove the filter, pull filter outwards.
- Wash the filter with clean water then dry.
- Re-install the filter, replace bucket.

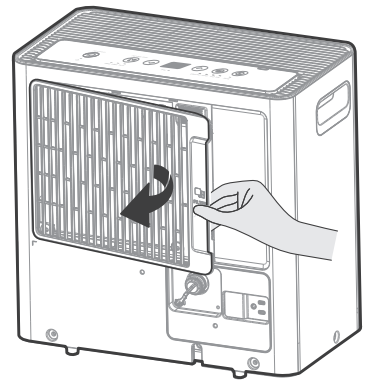

Fig. 8

CAUTION

DO NOT operate the dehumidifier without a filter because dirt and lint will clog it and reduce performance

4. Clean the pump filter

- Clean the pump filter every two weeks based on normal operating conditions.
- Take out the side access tank from the unit and remove the bucket top cover. (as shown as Fig. 9)
- Remove the screw as shown as Fig. 10.
- Take out the pump drainage structure and clean the filter at the button of the hose.
- Reinstall the filter and pump drainage structure to the side access tank.

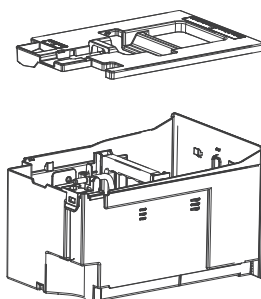

Fig. 9

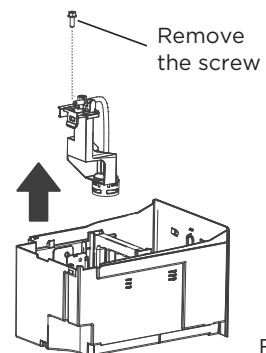
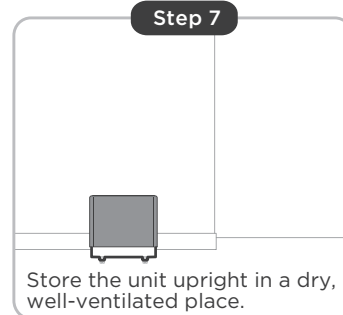
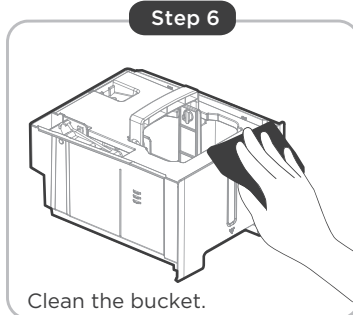
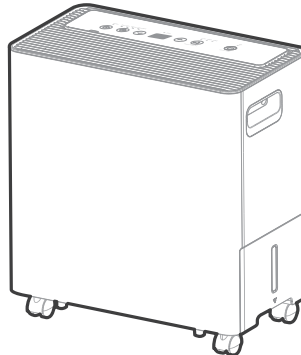
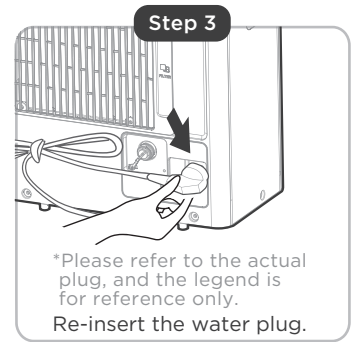
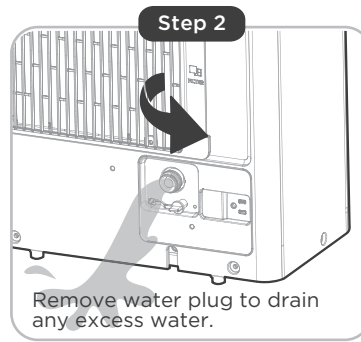
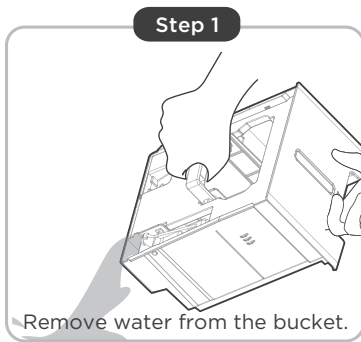

Fig. 10

When Not Using The Unit For Long Time Periods



- Clean the main unit, side access tank and air filter.
- It is normal that the water tray will have a small amount of water droplets to the chassis after take out the bucket. Please dry it off.
- Wrap the cord with the power cord buckle.
- Properly restore the bucket and place the unit in an upright position.
- Cover the unit with a plastic bag.
- Store the unit upright in a dry, well-ventilated place.

TROUBLESHOOTING TIPS

Malfunction Diagnosis

Before calling for service, review the chart below first. This list includes common occurrences that are not the result of defective workmanship or materials in this appliance.

Problem	What to check
Unit does not start	Make sure the dehumidifiers plug is pushed completely into the outlet.
	Check the house fuse/circuit breaker box.
	Dehumidifier has reached its preset level or bucket is full.
	Side access tank is not in the proper position.
Dehumidifier does not dry the air as it should	Did not allow enough time to remove the moisture
	Make sure there are no curtains, blinds or furniture blocking the front or back of the dehumidifier.
	The humidity control may not be set low enough.
	Check that all doors, windows and other openings are securely closed.
	Room temperature is too low, below 5°C (41°F).
The unit makes a loud noise when operating	There is a kerosene heater or something giving off water vapor in the room.
	Air filter may be dirty. Clean filter. Refer to Care and Maintenance section.
	The unit is tilted instead of upright as it should be.
	The floor surface is not level.
Frost appears on the coils	This is normal. The dehumidifier has an Auto defrost feature.
Water is leaking onto the floor	Hose to connector or hose connection may be loose.
	Intended to use the bucket to collect water, but the back drain plug is removed.
ES, AS, P2, Eb appear in the display	These are error codes and protection codes. See the CONTROL PANEL FEATURES section.
The pump operation on light blinks at 1 Hz	Clean the filter of the pump.
	Check the pump hose is not blocked or leaking.
	Empty the side access tank.

The design and specifications are subject to change without prior notice for product improvement. Consult with the sales agency or manufacturer for details. Any updates to the manual will be uploaded to the service website, please check for the latest version.

WARRANTY

Dehumidifier Limited Warranty

Your product is protected by this Limited Warranty:

Warranty service must be obtained from Midea Consumer Services or an authorized Midea servicer.

Warranty

- One Year full warranty from original purchase date.

Midea, through its authorized servicers will:

- Pay all costs for repairing or replacing parts of this appliance which prove to be defective in materials or workmanship.

Consumer will be responsible for:

- Diagnostics, removal, transportation and reinstallation cost required because of service.
- Costs of service calls that are a result of items listed under NORMAL RESPONSABILITIES OF THE CONSUMER**

Midea replacement parts shall be used and will be warranted only for the original warranty.

NORMAL RESPONSABILITIES OF THE CONSUMER**

This warranty applies only to products in ordinary household use, and the consumer is responsible for the items listed below:

1. Proper use of the appliance in accordance with instructions provided with the product.
2. Routine maintenance and cleaning necessary to keep the good working condition.
3. Proper installation by an authorized service professional in accordance with instructions provided with the appliance and in accordance with all local plumbing, electrical and/or gas codes.
4. Proper connection to a grounded power supply of sufficient voltage, replacement of blown fuses, repair of loosen connections or defects in house wiring.
5. Expenses for making the appliance accessible for servicing.
6. Damages to finish after installation.

EXCLUSIONS

This warranty does not cover the following:

- 1) Failure caused by damage to the unit while in your possession (other than damage caused by defect or malfunction), by its improper installation, or by unreasonable use of the unit, including without limitation, failure to provide reasonable and necessary maintenance or to follow the written installation and Operating Instructions.
- 2) Damages caused by serviced performed by persons other than those authorized by Midea customer service; or external causes such as abuse, misuse, inadequate power supply or acts of God.
- 3) If the unit is put to commercial, business, rental, or other use or application other than for consumer use, we make no warranties, express or implied, including but not limited to, any implied warranty of merchantability or fitness for use or purpose.
- 4) Products without original serial numbers or products that have serial numbers which have been altered or cannot be readily determined.

NOTICE: Some states do not allow the exclusions or limitation of incidental or consequential damages. So this limitation or exclusion may not apply to you.

IF YOU NEED SERVICE

Keep your bill of sale, delivery slip, or some other appropriate payment Record.

The date on the bill establishes the warranty period, should service be required.

If service is performed, its your best interest to obtain and keep all receipts.

This written warranty gives you specific legal rights. You may also have other rights that vary from state to state.

Service under this warranty must be obtained by following these steps, in order:

- 1) Contact Midea Consumer Services or an authorized Midea services at 1 866 646 4332.
- 2) If there is a question as to where to obtain service, contact our consumer relations Department.

RETURN POLICY

Return policy

Questions about installing or operating your Midea product?

- If you still need assistance, please call Customer Service at 1-866-646-4332.
- Have your sales receipt, serial number and product model number available when you call.

The product may be returned within 30 days of purchase with receipt. After 30 days, the product is covered under limited warranty.

Please refer to the warranty section in the User Manual for details.

**save your
receipt**





make yourself at home



www.midea.com

© Midea 2023 all rights reserved

MADSW

16120100A19535