

The Midea logo is located in the top right corner of the page. It consists of a blue square containing the word "Midea" in white, with a stylized white circle to the left of the letter 'M'.

Window Air Conditioner

MAW

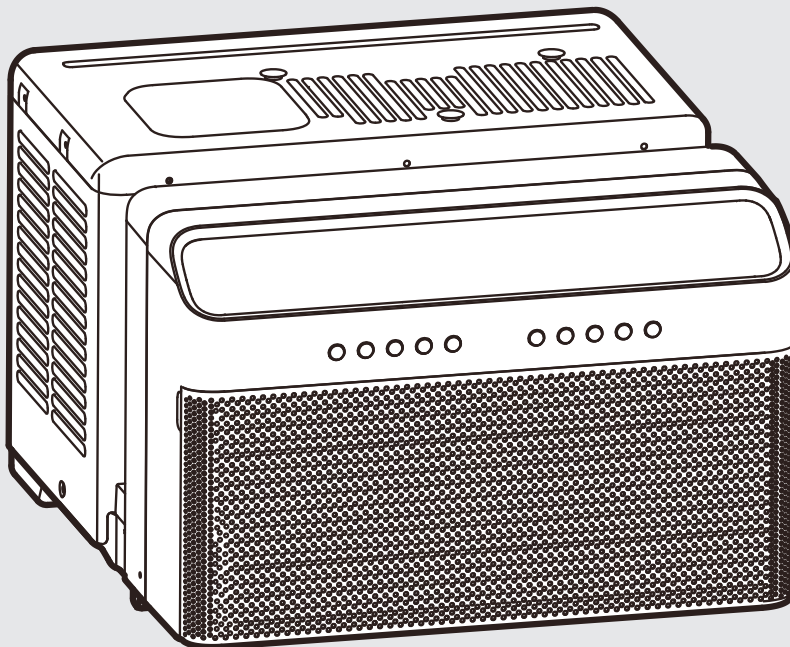

## USER MANUAL

MAW08W1QWT

MAW10W1QWT

MAW12W1QWT

Warning notices: Before using this product, please read this manual carefully and keep it for future reference.

The design and specifications are subject to change without prior notice for product improvement.

Consult with the dealer or manufacturer for details.

The diagram above is just for reference. Please take the appearance of the actual product as the standard.

THANK YOU FOR CHOOSING MIDEA!

Before using your new Midea product, please review this manual thoroughly to ensure safe and effective operation of its features and functions.

## CONTENTS

CONTENTS.....	2
SAFETY INSTRUCTIONS.....	3
PRODUCT INSTALLATION.....	12
OPERATION INSTRUCTIONS.....	18
REMOTE CONTROL AND SMART APP SETUP .....	23
CLEANING AND MAINTENANCE.....	41
TROUBLESHOOTING TIPS.....	42
TRADEMARKS, COPYRIGHTS AND LEGAL STATEMENT .....	44
DATA PROTECTION NOTICE.....	45
WARRANTY.....	46

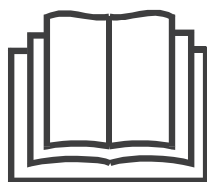







**IMPORTANT NOTE:** Read this manual carefully before installing or operating your new air conditioning unit. Make sure to save this manual for future reference.

# SAFETY INSTRUCTIONS

## Safety and Inspection Guidelines

These guidelines are provided to prevent risks and damage from unsafe operation of the unit. Inspect the packaging and unit upon arrival to ensure integrity. If any damage is found, contact the retailer or dealer immediately. Modifications or alterations to the unit are prohibited. Unintended use may result in hazards and void warranty claims.

### Explanation of symbols

	<p>Warning This symbol indicates that the unit uses a flammable refrigerant. If the refrigerant leaks and comes into contact with an ignition source, there is a risk of fire.</p>
	<p>Caution This symbol indicates that the operation manual should be read carefully.</p>
	<p>Caution This symbol indicates that a service personnel should be handling this equipment with reference to the installation manual.</p>
	<p>Caution This symbol indicates operating and installation instructions.</p>
	<p>Warning This signal indicates a medium-level hazard that, if not avoided, could result in death or serious injury.</p>
	<p>Caution This signal indicates a hazard with a low degree of risk which, if not avoided, may result in a minor or moderate injury.</p>
	<p>Attention This signal indicates important information (i.e. prevent property damage) but does not represent danger.</p>



Caution: Risk of fire/flammable materials

For support, please call the Service Center at 1-866-646-4332.

Service Center Operation Hours: Monday through Friday 8 a.m. to 7 p.m. EST  
Saturday 9 a.m. to 4 p.m. EST

### CAUTION

- This unit is not intended for use by people (including children) with reduced physical, sensory, or mental capabilities or lack of experience and knowledge, unless they have been given supervision or instruction concerning use of the unit by a person responsible for their safety.
- Children should be supervised to ensure that they do not play with the unit.
- The unit shall be installed in accordance with national wiring regulations.
- Do not operate the air conditioner in a humid room such as a bathroom or laundry room.



## WARNING

- Be sure the air conditioner has been securely and correctly installed according to the installation instructions in this manual. Save this manual for future reference when removing or re-installing this unit.
- Plug in power cord plug properly.
- Do not modify power cord length or share the outlet with other appliances.
- Always ensure effective grounding.
- Unplug the unit if unusual sounds, smells or smoke are from it.
- Ventilate room before operating the air conditioner if there is a gas leakage from another appliance.
- Do not operate or stop the unit by inserting or pulling out the power cord plug.
- Do not operate with wet hands or in very humid environments.
- Do not allow water to come into contact with any electric parts.
- Do not use the socket if it is loose or damaged.
- Do not use or keep the power cord close to heating appliances.
- Do not use any devices or materials for installation that are not recommended in this manual.
- Do not disassemble or modify unit.
- Do not damage or use an alternate power cord.  
If the power cord is damaged, it must be replaced by the manufacturer or an authorized service center or a similarly qualified person in order to avoid a hazard.
- Avoid directing the unit's airflow directly towards individuals to prevent potential health risks.
- Do not open the unit during operation.
- Do not use the power cord near flammable gas or combustibles. (i.e. gasoline, benzene, thinner etc)
- Do not let children hang onto the air conditioner or bracket.
- Do not use an extension cord or an adapter plug or remove any prongs from the power cord.
- Ensure the unit is properly grounded using the three-prong plug to enhance electrical safety.
- Use the unit with a properly grounded wall receptacle. If the receptacle is not adequately grounded or protected by a time-delay fuse or circuit breaker, have a qualified electrician install a suitable one. Ensure the receptacle remains accessible after the unit is installed.
- Verify that the electrical service meets the requirements for the specific model. Refer to the serial plate on the side of the cabinet, behind the grille, for this information.
- Do not ingest water drained from the unit.



## CAUTION

- Turn off the unit and switch off the circuit breaker before cleaning. Do not touch the metal parts of the unit when removing the air filter.
- Turn off the unit and switch off the circuit breaker before cleaning.
- Do not place obstacles around air inlets or inside of air outlet.
- Clean with a soft cloth only. Do not use strong detergents that contain wax or thinners.
- Use caution when unpacking and installing.
- Do not clean the unit with water.
- Do not put a pet or house plant where it will be exposed to direct air flow.
- Hold the plug by the head of the power plug when taking it out.
- Ensure that the installation is properly secured to prevent the product from potentially falling.
- Do not place heavy objects on the power cord and ensure that the cord is not compressed.
- If water spills on the unit, turn it off, switch off the circuit breaker, unplug the power supply and contact customer service.
- Do not use near gas stove or other gas burning appliances, as air flow may affect gas combustion.
- Do not use for any purpose other than room comfort.  
Do not use this air conditioner to preserve precision devices, food, pets, plants, and art objects. It may cause deterioration.
- Turn off the main power switch if the unit is not to be used for an extended time.
- Always insert the filters securely. Clean filter once every two weeks. See filter care instructions on page 41.

## Electronic Work

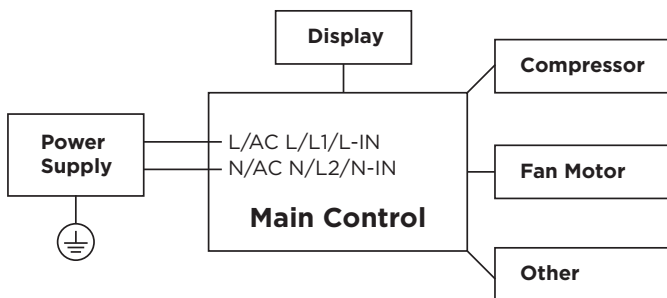

**NOTE:** Please strictly follow the wiring label attached to the machine for all wiring connections. The wiring diagram may vary for different unit. Please refer to the wiring diagram on the machine. The above wiring diagram is a simplified version for preliminary illustration purposes only.

## WARNING:

BEFORE PERFORMING ANY ELECTRICAL OR WIRING WORK, TURN OFF THE MAIN POWER TO THE SYSTEM.

## **WARNING**

- Servicing shall only be performed as recommended by the equipment manufacturer. Maintenance and repair requiring the assistance of other skilled personnel shall be carried out under the supervision of a person competent in the use of flammable refrigerants.
- DO NOT modify the length of the power cord or use an extension cord to power the unit.
- DO NOT share a single outlet with other electrical appliances. Improper power supply can cause fire or electrical shock.
- Please follow the instructions carefully to handle, install, clean and service the unit to avoid any damage or hazard.

## **WARNING**

### **Flammable!**

Refrigerant R32 is used within the unit.

- When maintaining or disposing the unit, the refrigerant (R32) shall be recovered properly, shall not discharge to air directly.
- Compliance with national gas regulations shall be observed.
- Keep ventilation openings clear of obstruction.
- The unit shall be stored so as to prevent mechanical damage from occurring.
- A warning that the unit shall be stored in a well-ventilated area where the room size corresponds to the room area as specified for operation.
- Any person who is involved with working on or breaking into a refrigerant circuit should hold a current valid certificate from an industry-accredited assessment authority, which authorizes their competence to handle refrigerants safely in accordance with an industry recognized assessment specification. All training shall follow the ANNEX HH requirements of UL 60335-2-40 4th Edition.

Examples for such working procedures are:

- Breaking into the refrigerating circuit;
- Opening of sealed components;
- Opening of ventilated enclosures.
- Keep the unit away from open flames or devices that may cause sparks to avoid igniting the flammable refrigerant, and follow instructions carefully to prevent mechanical damage.
- Do not use means to accelerate the defrosting process or to clean, other than those recommended by the manufacturer.
- The unit shall be stored in a room without continuously operating ignition sources (i.e. open flames, an operating gas appliance) and ignition sources (i.e. an operating electric heater) close to the unit.
- Do not pierce or burn.
- Be aware that the refrigerants may not contain an odor.

## How To Handle Equipment Containing Flammable Refrigerants

### 1. Transport of equipment containing flammable refrigerants.

See transport regulations.

### 2. Marking of equipment using signs.

See local regulations.

### 3. Disposal of equipment using flammable refrigerants.

See national regulations.

### 4. Storage of equipment.

The storage of the appliance should be in accordance with the applicable regulations or instructions, whichever is more stringent.

### 5. Storage of packed (unsold) unit.

Storage package protection should be constructed such that mechanical damage to the unit inside the package will not cause a leak of the refrigerant charge. The maximum number of pieces of equipment permitted to be stored together will be determined by local regulations.

### 6. Information on servicing.

#### 1) Checks to the area

Prior to beginning work on systems containing flammable refrigerants, safety checks are necessary to ensure that the risk of ignition is minimized. For repair to the refrigerating system, the following precautions shall be complied with prior to conducting work on the system.

#### 2) Work procedure

Work shall be undertaken under a controlled procedure so as to minimize the risk of a flammable gas or vapor being present while the work is being performed.

#### 3) General work area

All maintenance staff and others working in the local area shall be instructed on the nature of work being carried out. Work in confined spaces shall be avoided. The area around the workspace shall be sectioned off. Ensure that the conditions within the area have been made safe by control of flammable material.

#### 4) Checking for presence of refrigerant

The area shall be checked with an appropriate refrigerating detector prior to and during work, to ensure the technician is aware of potentially flammable atmospheres. Ensure that the leak detection equipment being used is suitable for use with flammable refrigerants. (i.e. non-sparking, adequately sealed or intrinsically safe).

#### 5) Presence of fire extinguisher

If any hot work is to be conducted on the refrigeration equipment or any associated parts, appropriate fire extinguishing equipment shall be available to hand. Have a dry powder or CO2 fire extinguisher adjacent to the charging area.

#### 6) No ignition sources

During work on refrigeration systems involving pipes containing or having contained flammable refrigerants, individuals must avoid using any ignition sources that could potentially cause fire or explosion risks. This includes maintaining a safe distance from the installation, repair, removal, and disposal sites where flammable refrigerants may be present. Before commencing work, the surrounding area must be inspected to ensure there are no flammable hazards or ignition risks. Additionally, 'No Smoking' signs should be prominently displayed.

#### 7) Ventilated area

Before initiating any system breach or conducting hot work, ensure the area is outdoors or properly ventilated. Adequate ventilation must be maintained throughout the duration of the work to safely disperse any released refrigerant, ideally venting it externally into the atmosphere.

8) Checks to the refrigerating equipment

When replacing electrical components, ensure they are suitable for their intended purpose and meet the correct specifications. Always adhere to the manufacturer's maintenance and service guidelines. If uncertain, seek guidance from the manufacturer's technical department. The following checks should be performed for installations utilizing flammable refrigerants:

The refrigerant charge must align with the size of the room where refrigerant-containing parts are installed. Ensure ventilation systems and outlets operate effectively and remain unobstructed. If using an indirect refrigerating circuit, verify the presence of refrigerant in the secondary circuit. Equipment markings must be visible and legible at all times; any illegible markings or signs should be promptly corrected. Refrigeration pipes and components should be installed in locations unlikely to expose them to corrosive substances, unless they are inherently corrosion-resistant materials or adequately protected against corrosion.

9) Checks to electrical devices

Repair and maintenance of electrical components must begin with initial safety checks and thorough inspection procedures. If a fault is identified that could pose a safety risk, no electrical supply should be connected to the circuit until the issue is resolved. If immediate correction of the fault isn't feasible but operation must continue, a suitable temporary solution must be implemented. This action should be promptly reported to the unit owner to ensure all parties are informed.

Initial safety checks shall include:

Ensure capacitors are discharged safely to prevent sparking. Ensure no live electrical components or exposed wiring during charging, recovering, or purging the system. Verify continuity of earth bonding throughout these procedures.

**7. Sealed electrical components shall be replaced.**

**8. Intrinsically safe components must be replaced.**

**9. Cabling.**

Check that cabling will not be subject to wear, corrosion, excessive pressure, vibration, sharp edges or any other adverse environmental effects. The check shall also take into account the effects of aging or continual vibration from sources such as compressors or fans.

**10. Detection of flammable refrigerants.**

Under no circumstances should potential sources of ignition be used during the search for or detection of refrigerant leaks. This includes avoiding the use of halide torches or any other detectors that utilize naked flames.

The following leak detection methods are deemed acceptable for systems containing flammable refrigerants. Electronic leak detectors shall be used to detect flammable refrigerants, but the sensitivity may not be adequate, or may need re-calibration.

(Detection equipment shall be calibrated in a refrigerant-free area).

Ensure that the detector is not a potential source of ignition and is suitable for the refrigerant used. Leak detection equipment shall be set at a percentage of the LFL of the refrigerant and shall be calibrated to the refrigerant employed and the appropriate percentage of gas (25% maximum) is confirmed. Leak detection fluids are suitable for use with most refrigerants but the use of detergents containing chlorine shall be avoided as the chlorine may react with the refrigerant and corrode the copper pipe-work.

If a leak is suspected, all naked flames shall be removed/extinguished. If a refrigerant leak requiring brazing is detected, all refrigerant must be recovered from the system, or isolated (using shut-off valves) in a part of the system away from the leak. Removal of refrigerant shall be according to "Removal and evacuation".

## How To Handle Equipment Containing Flammable Refrigerants (cont.)

### 11. Removal and evacuation.

When breaking into the refrigerant circuit to make repairs - or for any other purpose - conventional procedures shall be used. However, for flammable refrigerants it is important that best practice be followed, since flammability is a consideration. The following procedure shall be adhered to:

- Safely remove refrigerant following local and national regulations;
- Evacuate;
- Purge the circuit with inert gas (optional for A2L);
- Evacuate (optional for A2L);
- Continuously flush or purge with inert gas when using flame to open circuit; and
- Open the circuit.

The refrigerant charge must be recovered into appropriate recovery cylinders if venting is prohibited by local and national codes. For appliances containing flammable refrigerants, the system should be purged with non-flammable refrigerants that are oxygen-free. Under no circumstances should compressed air or oxygen be used for purging refrigerant systems.

For appliances containing flammable refrigerants, purging must be conducted by initially breaking the vacuum in the system with oxygen-free nitrogen. Nitrogen should be continuously added until the desired working pressure is reached, then vented to the atmosphere. Subsequently, the system should be pulled down to a vacuum (this step is optional for A2L refrigerants). This purging process should be repeated until no refrigerant remains in the system (optional for A2L refrigerants). After the final charge of oxygen-free nitrogen is used, the system should be vented to atmospheric pressure to facilitate further work.

The outlet for the vacuum pump shall not be close to any potential ignition sources, and ventilation shall be available.

The refrigerant charge shall be recovered into the correct recovery cylinders if venting is not allowed by local and national codes. For appliances containing flammable refrigerants, the system shall be purged with oxygen-free nitrogen to render the appliance safe for flammable refrigerants. This process might need to be repeated several times. Compressed air or oxygen shall not be used for purging refrigerant systems. For appliances containing flammable refrigerants, refrigerants purging shall be achieved by breaking the vacuum in the system with oxygen-free nitrogen and continuing to fill until the working pressure is achieved, then venting to atmosphere, and finally pulling down to a vacuum (optional for A2L). This process shall be repeated until no refrigerant is within the system (optional for A2L). When the final oxygen-free nitrogen charge is used, the system shall be vented down to atmospheric pressure to enable work to take place. Ensure that the outlet for the vacuum pump is not close to any potential ignition sources and that ventilation is available.

### 12. Charging procedures.

In addition to conventional charging procedures, the following requirements shall be followed. Ensure that contamination of different refrigerants does not occur when using charging equipment. Hoses or lines shall be as short as possible to minimize the amount of refrigerant contained in them. Cylinders shall be kept in an appropriate position according to the instructions. Ensure that the refrigeration system is earthed prior to charging the system with refrigerant. Label the system when charging is complete (if not already). Extreme care shall be taken not to overfill the refrigeration system. Prior to recharging the system it shall be pressure tested with OFN. The system shall be leak tested on completion of charging but prior to commissioning. A follow up leak test shall be carried out prior to leaving the site.

### 13. Decommissioning.

Before carrying out this procedure, it is essential that the technician is completely familiar with the unit and all its detail. It is recommended good practice that all refrigerants are recovered safely. Before commencing the task, it is essential to take oil and refrigerant samples in case analysis is needed before reclaimed refrigerant can be reused. Ensure electrical power is available prior to starting the task.

- a. Become familiar with the equipment and its operation.
- b. Isolate system electrically.
- c. Before attempting the procedure ensure that mechanical handling equipment is available if required for handling refrigerant cylinders;  
All personal protective equipment is available and being used correctly; The recovery process is supervised at all times by a competent person; Recovery equipment and cylinders conform to the appropriate standards.
- d. If possible, pump down the refrigerant system.
- e. If a vacuum is not possible, make a manifold so that refrigerant can be removed from various parts of the system.
- f. Make sure that cylinder is situated on the scales before recovery takes place.
- g. Start the recovery machine and operate in accordance with instructions.
- h. Do not overfill cylinders. (No more than 80% volume liquid charge).
- i. Do not exceed the maximum working pressure of the cylinder, even temporarily.
- j. When the cylinders have been filled correctly and the process completed, make sure that the cylinders and the equipment are removed from site promptly and all isolation valves on the equipment are closed off.
- k. Recovered refrigerant shall not be charged into another refrigeration system unless it has been cleaned and checked.

### 14. Labeling.

Equipment shall be labeled stating that it has been de-commissioned and emptied of refrigerant. The label shall be dated and signed.

Ensure that there are labels on the unit stating the unit contains flammable refrigerant.

### 15. Recovery.

When removing refrigerant from a system, either for servicing or decommissioning, it is recommended good practice that all refrigerants are removed safely.

When transferring refrigerant into cylinders, ensure that only appropriate refrigerant recovery cylinders are employed. Ensure that the correct number of cylinders for holding the total system charge is available. All cylinders to be used are designated for the recovered refrigerant and labeled for that refrigerant (i.e. special cylinders for the recovery of refrigerant). Cylinders shall be complete with pressure-relief valve and associated shut-off valves in good working order. Empty recovery cylinders are evacuated and, if possible, cooled before recovery occurs.

The recovery unit shall be in good working order with a set of instructions concerning the unit that is at hand and shall be suitable for the recovery of the flammable refrigerant. If in doubt, the manufacturer should be consulted. In addition, a set of calibrated weighing scales shall be available and in good working order. Hoses shall be complete with leak-free disconnect couplings and in good condition.

The recovered refrigerant shall be processed according to local legislation in the correct recovery cylinder, and the relevant waste transfer note arranged. Do not mix refrigerants in recovery units and especially not in cylinders.

If compressors or compressor oils are to be removed, ensure that they have been evacuated to an acceptable level to make certain that flammable refrigerant does not remain within the lubricant. The compressor body shall not be heated by an open flame or other ignition sources to accelerate this process. When oil is drained from a system, it shall be carried out safely.

Non-duct connected appliances containing A2L refrigerants with the supply and return air openings in the conditioned space may have the body of the appliance installed in open areas such as false ceilings not being used as return air plenums, as long as the conditioned air does not directly communicate with the air of the false ceiling.

## Operation of Current Device

The power supply cord contains a current measuring device that detects damage to the power cord. Test the power supply cord as follows:

1. Plug in the air conditioner.
2. The power supply cord will have TWO buttons on the plug head. Press the TEST button. A click will be heard as the RESET button pops out.
3. Press the RESET Button. A click will be heard as the button engages.
4. The power supply cord is now supplying electricity to the unit. (On some units this is also indicated by a light on the plug head.)

### NOTE

The power supply cord with this air conditioner contains a current detection device designed to reduce the risk of fire.

In the event that the power supply cord is damaged, it can not be repaired. It must be replaced with a cord from the manufacturer.

### NOTE

- Do not use this device to turn the unit on or off.
- Always make sure the RESET button is pushed in for correct operation.
- If the power supply cord does not reset when the TEST button is pressed or cannot be reset, it must be replaced. Please contact customer service for assistance.

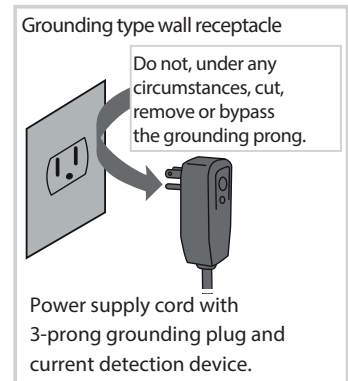
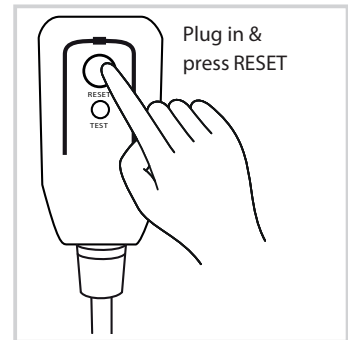

# PRODUCT INSTALLATION

## Installation Video

Scan the QR code to watch an installation video of the Midea U.

If the power supply cord does not reset when the TEST button is pressed or cannot be reset, it must be replaced. Please contact customer service for assistance.

It is highly recommended to watch the video before proceeding with the installation process.



## WARNING - Before Beginning

Read these instructions completely and carefully.

- Save these instructions.
- Observe all governing codes and ordinances.

We recommend that two people install this unit.

Proper installation is the responsibility of the installer.

Product failure due to improper installation is not covered under the Limited Warranty.

All supplied parts must be used, and proper installation procedures outlined in these instructions must be followed when installing this air conditioner.

Do not, under any circumstances, cut or remove the third (ground) prong from the power cord.

Do not change the plug on the power cord of the unit.

Aluminum house wiring may present special problems - consult a qualified electrician.

When handling the unit, be careful to avoid cuts from sharp metal edges and aluminum fins on front and rear coils. Please wear cut-resistant gloves.

Bracket should only be used for its intended purpose. Failure to do so will void the warranty.

## Window Requirements

This unit is designed to be installed in a standard double hung window with opening widths of 22" to 36" (55.8cm to 91.4cm) and a window height of 13.75" (34.9 cm).

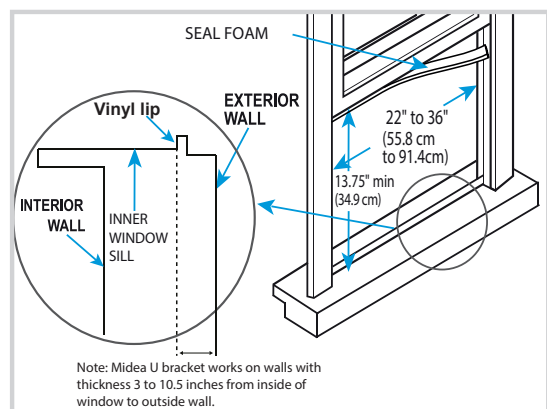



## Required Tools

Phillips screwdriver

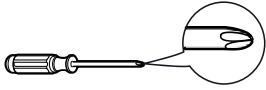

Level



Flathead screwdriver



Pencil

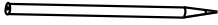

Ruler or tape measure

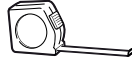

Scissors or knife



Drill and 1/8" drill bit

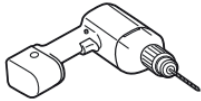

Proper PPE

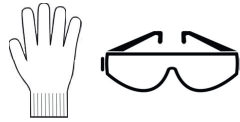

\*Not Included

### NOTE







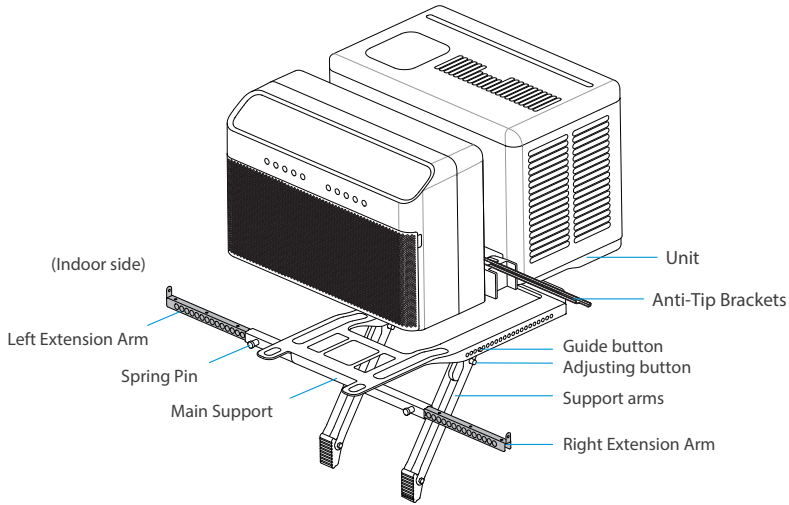



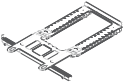

Save carton and these Installation Instructions for future reference. The carton is the best way to store unit during winter, or when not in use. If any piece of hardware is missing, DO NOT INSTALL THE PRODUCT, and call customer service at 1-866-646-4332.

# Install AC Support bracket and AC

Installation exploded view:



## Installation Hardware:

NO.	Mounting Hardware		Qty.	NO.	Mounting Hardware		Qty.
A1		Main Bracket	1	B1		Side Arm Foam	2
				B2		Window Sash Lock	1
A2		Right Extension Arm (For 26"-36" windows)	1	B3		Window Sash Foam	1
A3		Right Extension Arm – Short (For 22"-26" windows)	1	B4		Window Sealing Foam	1
A4		1/2" Type A Screw	2	B5		Bracket Sealing Foam	1
A5		1" Type A Screw	2	B6		Additional Side Arm Foam	2
A6		1.5" Type A Screw	2	B7		Flat Sill Adapter (for flat sill windows)	1

\*Indicates additional hardware provided in separate bags for certain models.

## Different type of Windows :

Determine whether the windowsill is flat or has a lip.

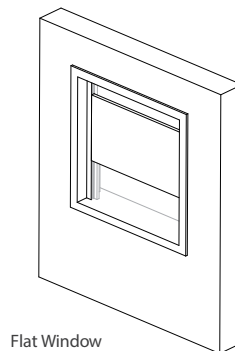
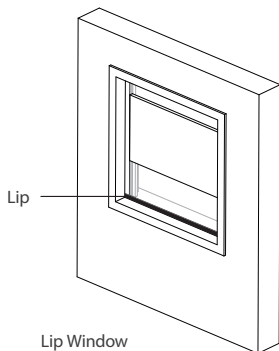

## Step 1 : Install Support Bracket (for Lip Window)

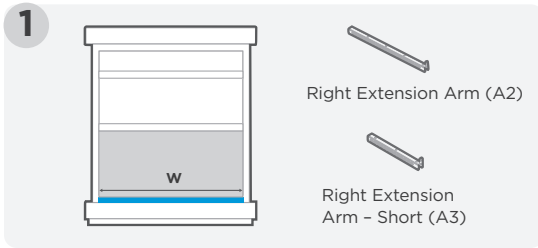

Select the proper extension arm based on the width of the window.  
Use Right Extension Arm - Short for 22-26". windows, and Right Extension Arm for 26-36". windows.

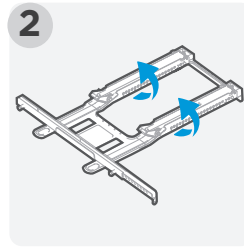

Remove the tape from the bracket (A1) and flip it over.

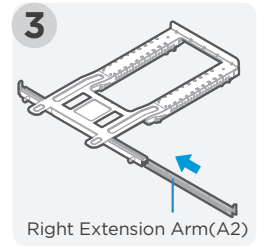

Insert the proper extension arm in the bracket as shown.

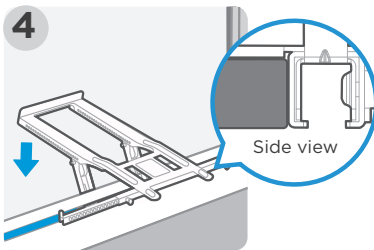

Place the bracket in the center of the window.  
**Ensure the main support is on the interior side of the lip.**

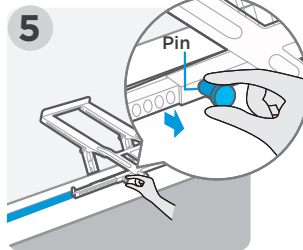

**Pull the spring pin** and slide the arm out until it contacts the window casing. Repeat on the other side.

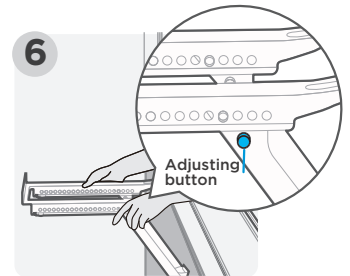

**Press the adjusting button** on each support arm to adjust the legs until they rest against the wall on the outside.

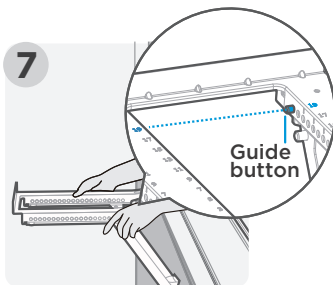

Ensure the guide button are protruding from the **same number hole** on each arm.

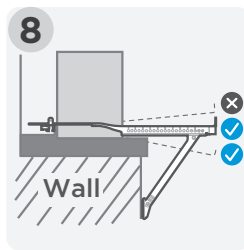

Ensure the bracket is level or angled slightly towards the outside.

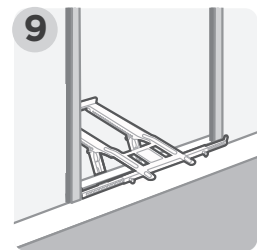

The bracket is ready for the unit to be installed.

## Step 1 : Install Support Bracket (for Flat Window)

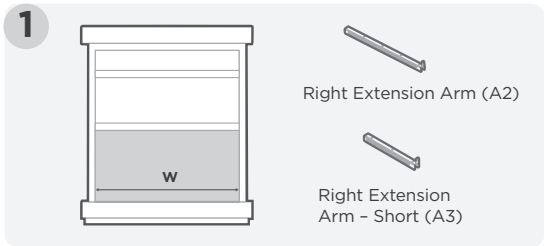

Select the proper extension arm based on the width of the window.  
Use Right Extension Arm - Short for 22-26". windows, and Right Extension Arm for 26-36". windows.

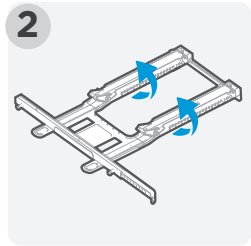

Remove the tape from the bracket and flip it over.

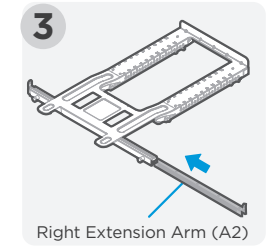

Insert the proper extension arm in the bracket as shown.

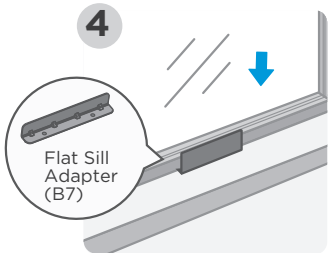

Place the flat sill adapter (B7) on the windowsill so that the window sash lowers just behind the vertical face of the adapter.

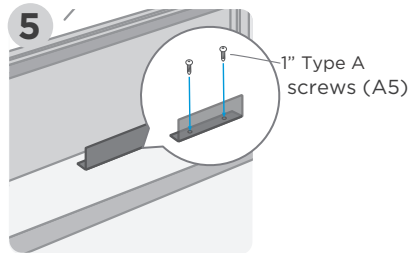

Secure the flat sill adapter (B7) to the window sill using 1" (A5) Type A screws.

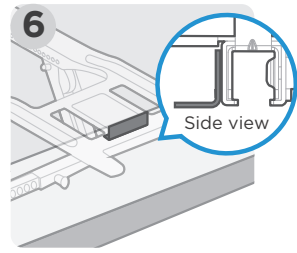

Place the bracket in the center of the window, with the main support resting on the interior side of the adapter.

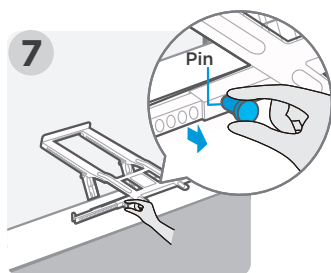

Pull the spring pin and slide the arm out until it contacts the window casing. Repeat on the other side.

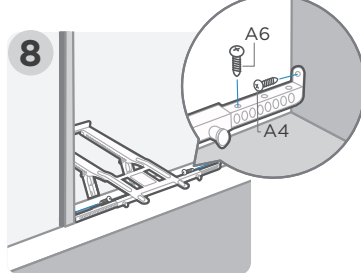

Secure it to the windowsill using the 1 - 1/2" (A6) Type A screws on both sides as shown. Use the 1/2" (A4) screws to fasten each extension arm to the wall as shown.

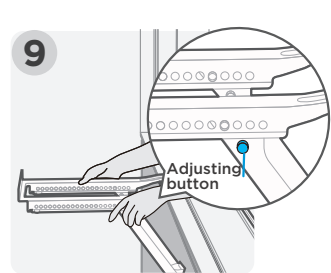

Press the adjusting button on each support arm to adjust the legs until they rest against the wall on the outside.

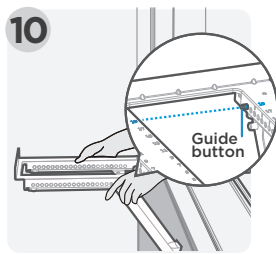

Ensure the guide buttons are protruding from the same number hole on each arm.

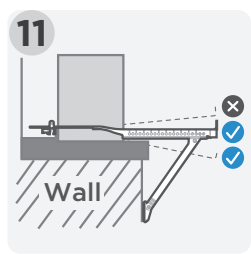

Ensure the bracket is level or angled slightly towards the outside.



The bracket is ready for the unit to be installed.

## Step 2 : Install Air Conditioner

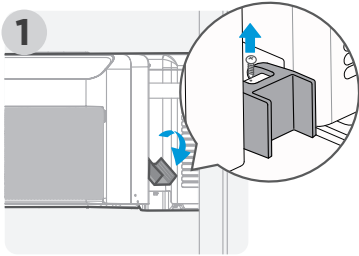

1 Fold down both side arm hinges and **remove the screw** on each side. Save these screws for the following step 3 and step 4 .

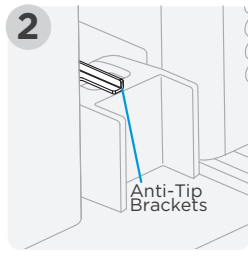

2 Remove the tape and slide out the anti-tip arms from each side about 1 inch through the opening in the side arm hinges.

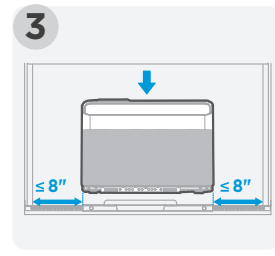

3 Place the AC unit on the bracket. Ensure it is centered in the window.

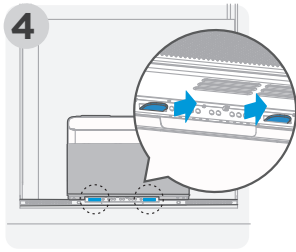

4 Carefully slide the unit out until the flanges on the bracket **pass through** the grooves on the bottom of the unit.

## Step 3 : Foam Installation

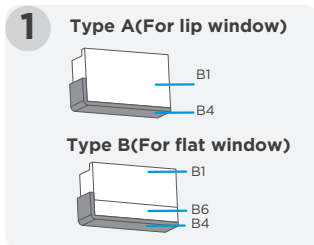

1 **Cut the side arm foam (B1) to length and attach the window sealing foam (B4)** and additional side arm foam (B6) as shown above based on the window type.

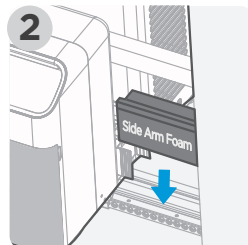

2 Insert the side arm foam (B1) on each side.

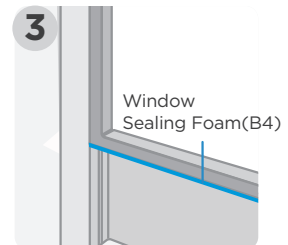

3 **Cut the adhesive window sealing foam (B4)** to the width of the window and attach it to the bottom of the windowpane.

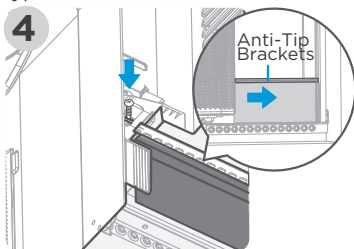

4 The anti-tip brackets must be extended into the window track opening (the vertical track the window slides up and down in) until they stop. Secure the brackets in place using the screws which were removed in step 1 and step 2.

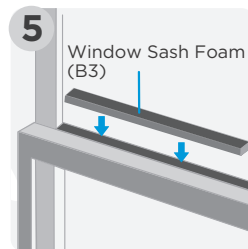

5 Cut window sash foam (B3) and insert it in the space between the upper and lower sashes.

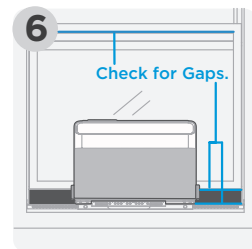

6 Installation is completed.

# OPERATION INSTRUCTIONS

## Normal Operating Sounds

### High Pitched Chatter

High efficiency compressors may have a high pitched sound during cooling cycle.

### Trickling Sound

Droplets of water hitting condenser during normal operation may cause a trickling sound.

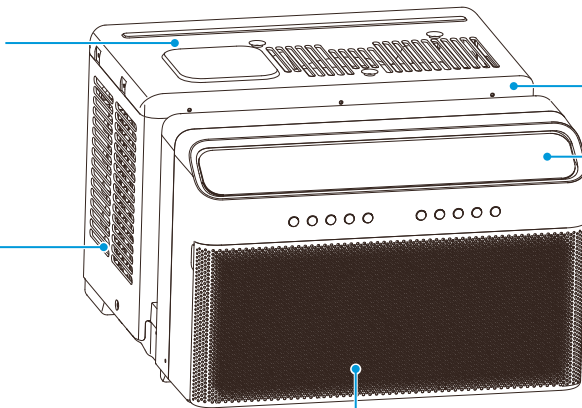

### Vibration

Unit may vibrate and make noise because of poor wall or window construction or incorrect installation.

### Sound of Rushing Air

In front of the unit, the sound of rushing air from the fan may be audible.

### Gurgle/Hiss

Gurgling or hissing noises may be heard due to refrigerant flowing through evaporator during normal operation.

## WARNING

To reduce the risk of fire, electrical shock, or injury to people or property, read the SAFETY PRECAUTIONS before operating this appliance.

Cooling Operation	Outdoor temp.: 64°F - 109°F / 18°C - 43°C
	Indoor temp.: 60°F - 90°F / 16°C - 32°C

### NOTE

- The relative humidity of the room should be less than 80%. If the unit is used in a condition with a relative humidity over 80%, there will be condensed water on the surface of the unit.
- Performance may be reduced outside of these operating temperatures.

### NOTE

Always wait 3 minutes when turning the unit off and then on again, or when changing from cool to fan and back to cool. This prevents damage from occurring to the compressor.

## To begin operating the air conditioner, follow these steps:

1. Plug in the air conditioner (be sure to follow the power cord instructions) on page 11.
2. Turn the power on to the air conditioner, using the ON/OFF button.
3. Set the thermostat to the coldest temperature setting.
4. Select the Cool mode setting.
5. Adjust the louver for comfortable air flow (see Air Directional Louvers).
6. Once the room has cooled, adjust the thermostat to the setting that is most comfortable.
7. Make sure the air flow inside and outside is not obstructed by anything.

### Air Directional Louvers

The louvers can direct airflow up or down and left or right as needed. Use the SWING button to adjust the up/down direction.

Move the louvers from side to side until the desired left/right direction is obtained.

Use SWING button for up/down direction

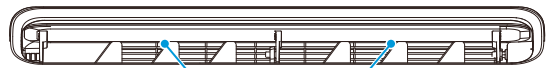
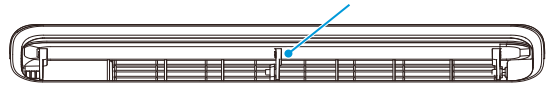

Adjust louvers for left/right direction

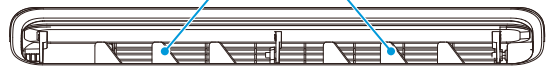

Air Direction

## Features

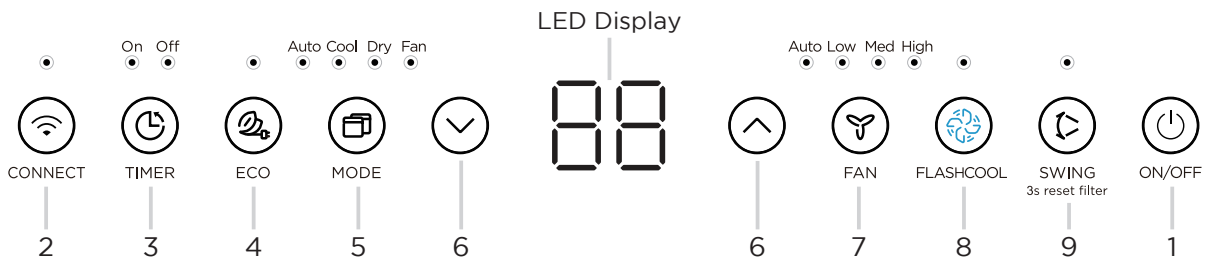

			Description
1		ON / OFF	Press to turn unit on or off.
2		Connect Function	Press to initiate smart connection mode.
3		Timer	Press to set timer feature on/off.
4		Energy Saver	Press to initiate this feature, which will maintain comfort and save energy.
5		Mode Functions	Press to choose operating mode in a sequence that goes from Auto, Cool, Dry and Fan.
6		Up/Down Button	Press to change temperature setting.
7		Fan Speed	Press to select the Fan Speed in four steps - Auto, Low, Med or High.
8		FlashCool Function	Press to initiate the FlashCool mode.
9		Swing / Check Filter	Press to initiate the auto swing feature. Press for 3 sec to turn off the clean filter reminder.

### 1. ON/OFF Button

Press ON/OFF button to turn unit on or off.

### 2. CONNECT Button

When connecting the unit to Wireless Connection, press the CONNECT button for 3 seconds to initiate the Wireless Connection mode.

The display shows 'AP' to indicate the unit is in the Wireless Connection mode. Refer to the Connect section for further instructions.

If connection (router) is successful within 8 minutes, the unit will exit Wireless Connection mode automatically and the CONNECT indicator illuminates.

If connection failed within 8 minutes, the unit exits Wireless Connection mode automatically and the CONNECT indicator does not illuminate.

After Wireless Connection is successful, press and hold CONNECT and DOWN (∨) buttons at the same time for 3 seconds to turn off CONNECT function and the LED DISPLAY shows 'OF' for 3 seconds, press CONNECT and UP (∧) buttons at the same time to turn on Connect function and the LED DISPLAY shows 'On' for 3 seconds.

### 3. Timer Button: Auto Start/Stop Feature

#### TIMER Button

- The TIMER button enables the AUTO OFF and AUTO ON features, which allows to set a desired time for the unit to turn off or on automatically.



To operate the AUTO OFF Feature

- While the unit is running, press the TIMER button once to enable the AUTO OFF feature.
- Press the UP and DOWN buttons to choose the desired time, in hours, to turn the unit off.

To operate the AUTO ON Feature

- When the unit is powered off, press the TIMER button once to enable the AUTO ON feature. Press the UP and DOWN buttons to choose the desired time, in hours, to turn the unit on.
- Turning the unit ON or OFF at any time or adjusting the timer setting to 0.0 will cancel the Auto Start/Stop timed program.

#### NOTE

To cancel timer operation, press and hold the timer button for 2 seconds until the beep/buzzer is heard.

#### 4. ECO Button

ECO mode is on by default, pressing it turns it off.

This function is available on COOL, DRY, and AUTO (only AUTO-COOLING and AUTO-FAN) modes.

The fan will continue to run for 3 minutes after the compressor shuts off.

The fan then cycles on for 2 minutes at 10 minute intervals until the room temperature is above the set temperature, at which time the compressor turns back on and Cooling Starts.

#### 5. MODE Button

- To choose the operating mode, press the MODE button. Each time the button is pressed, a mode is selected in a sequence that goes from Auto, Cool, Dry and Fan. The indicator light beside the button will be illuminated and remain on once that mode is selected.
- When the unit is turned off and back on via the power button, the unit will automatically switch on the Energy Saver Function for the following modes: Cool, Dry, Auto.

To operate on AUTO mode:

- In AUTO mode, the air conditioner will automatically select either cooling or fan-only operation based on the selected temperature and the current room temperature.
- The air conditioner will automatically control the room temperature according to the set temperature.
- In this mode, the fan speed cannot be adjusted and is automatically controlled based on the temperature setting and room temperature.

To operate on COOL mode:

- Choose Cool Mode to set the cooling function. Use the UP (∧) or DOWN (∨) buttons to choose the desired temperature. When Cool Mode is selected, the fan speed can be adjusted by pressing the fan button.

To operate on DRY mode:

- In this mode, the air conditioner will generally operate as a dehumidifier. Since the conditioned space is a closed or sealed area, some degree of cooling will continue. On Dry mode, the fan speed is not adjustable.

To operate on FAN mode:

- Use this function only when cooling is not desired, such as for room air circulation. Any fan speed can be selected.
- In Fan Only mode, the temperature cannot be adjusted and the display will show the actual room temperature, not the set temperature as in the cooling mode.

#### 6. UP/DOWN Button

Press UP (∧) or DOWN (∨) button to change temperature setting.

#### 7. FAN SPEED Button

Press Fan button to select the Fan Speed in four steps - Auto, Low, Med or High. Each time the button is pressed, the fan speed mode is shifted.

#### 8. FLASHCOOL Button

Press to turn FlashCool on or off. In FlashCool mode, the air conditioner will run at the highest fan speed and compressor speed to provide additional cooling to reach the temperature setpoint. Once the setpoint is reached, the unit will continue to run the fan in high speed and stay in FlashCool mode. FlashCool mode will end if:

- Button is pressed again
- The unit is turned off
- The mode is changed
- The fan speed is changed
- Sleep mode is enabled.

#### 9. SWING Button

Use the SWING button to initiate the auto swing feature for the outlet louver. When the auto swing is on, pressing the SWING button can stop the louver at the desired angle.

#### Check Filter Feature:

The Check Filter feature is a reminder to clean the air filter for a more efficient operation. The light above the button will illuminate after 250 hours of operation. After cleaning the filter, press the SWING button for 3 seconds to reset the Check Filter feature turning the light off. See page 41 for filter cleaning instructions.

## Displays

#### LED Display:

Shows the set temperature in "°C" or "°F" and the Auto-timer settings. While on Fan Only mode, it shows the room temperature. If the room temperature is too high or low, it will display "HI" or "LO".

To change between °F and °C, press and hold the UP (^) and DOWN (v) buttons at the same time for 3 seconds.



#### Error codes:

The unit may stop operation due to a malfunction with the unit. If this occurs, an error code may appear on the display like below.

Wait 10 minutes as the problem may resolve itself. If not, disconnect the power, then connect it again. Turn the unit on.

If the problem persists, disconnect the power and contact customer service.

Error codes appear and begin with the letters as noted below in the window display of the indoor unit:

EH(xx), EL(xx), EC(xx), PH(xx), PL(xx), PC(xx).

#### NOTE

If the unit turns off unexpectedly due to the power being cut, it will automatically restart with the previous function setting when the power resumes.

# REMOTE CONTROL AND SMART APP SETUP

## Location of the remote control

Use the remote control within a distance of 26 ft. (8m) from the air conditioner, pointing it towards the unit. The unit will beep when it receives a signal.

### CAUTION

- The air conditioner will not operate if curtains, doors or other materials block the signals from the remote control to the unit.
- Prevent any liquid from spilling onto the remote control. Do not expose the remote control to direct sunlight or heat.
- If the infrared signal receiver on the indoor unit is exposed to direct sunlight, the air conditioner may not function properly. Use curtains to prevent the sunlight from falling on the receiver.
- If other electrical appliances react to the remote control, either move these appliances or consult the local dealer.

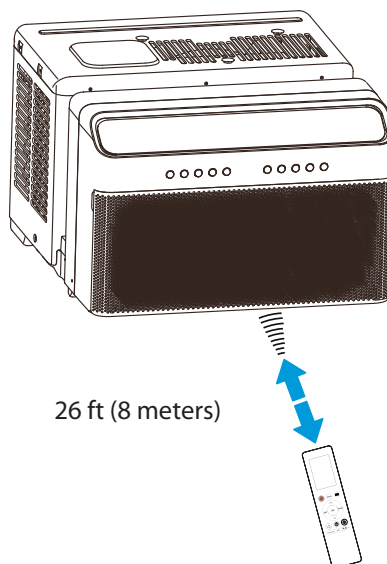

## Inserting and Replacing Batteries

The unit comes with 2 AAA batteries. Put the batteries in the remote control before use.

1. Slide the back cover of the remote control outward to reveal the battery compartment.
2. Insert the batteries, ensuring the (+) and (-) ends align with the symbols inside the battery compartment.
3. Slide the battery cover back into place.

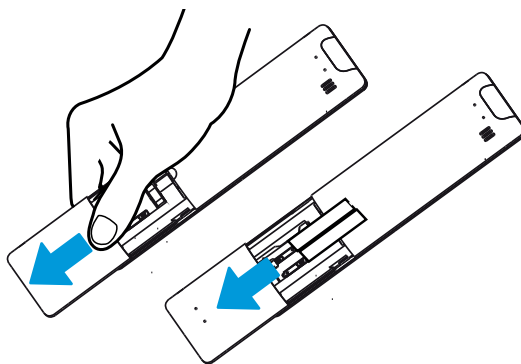

## Remote Control Specifications

Rated Voltage	3.0V (Dry batteries R03/LR03x2)
Signal Receiving Range	26 ft (8 m)
Environment	-5 °C ~ 60 °C (23°F ~ 140°F)

## Notes

The unit could comply with the local national regulations.

- In Canada, it should comply with CAN ICES-3(B)/NMB-3(B).
- In USA, this unit complies with part 15 of the FCC Rules. Operation is subject to the following two conditions:

(1) This unit may not cause harmful interference, and

(2) This unit must accept any interference received, including interference that may cause undesired operation.

This unit has been tested and found to comply with the limits for a Class B digital device, pursuant to part 15 of the FCC Rules. These limits are designed to provide reasonable protection against harmful interference in a residential installation. This unit generates, uses and can radiate radio frequency energy and, if not installed and used in accordance with the instructions, may cause harmful interference to radio communications. However, there is no guarantee that interference will not occur in a particular installation. If this unit does cause harmful interference to radio or television reception, which can be determined by turning the unit off and on, the user is encouraged to try to correct the interference by one or more of the following measures:

- Reorient or relocate the receiving antenna.
- Increase the separation between the unit and receiver.
- Connect the unit into an outlet on a circuit different from that to which the receiver is connected.
- Consult the dealer or an experienced radio/TV technician for help.
- Changes or modifications not approved by the party responsible for compliance could void user's authority to operate the unit.

## Battery Warning

- Do not mix old and new batteries, or batteries of different types.
- Always purchase the correct size and grade of battery most suitable for the intended use.
- Replace all batteries of a set at the same time.
- Clean the battery contacts and those of the unit before installing the batteries.
- Remove batteries from the remote control when not in use for an extended period.
- Remove used batteries promptly.
- Dispose of used batteries according to local laws and regulations.

# Buttons and Functions

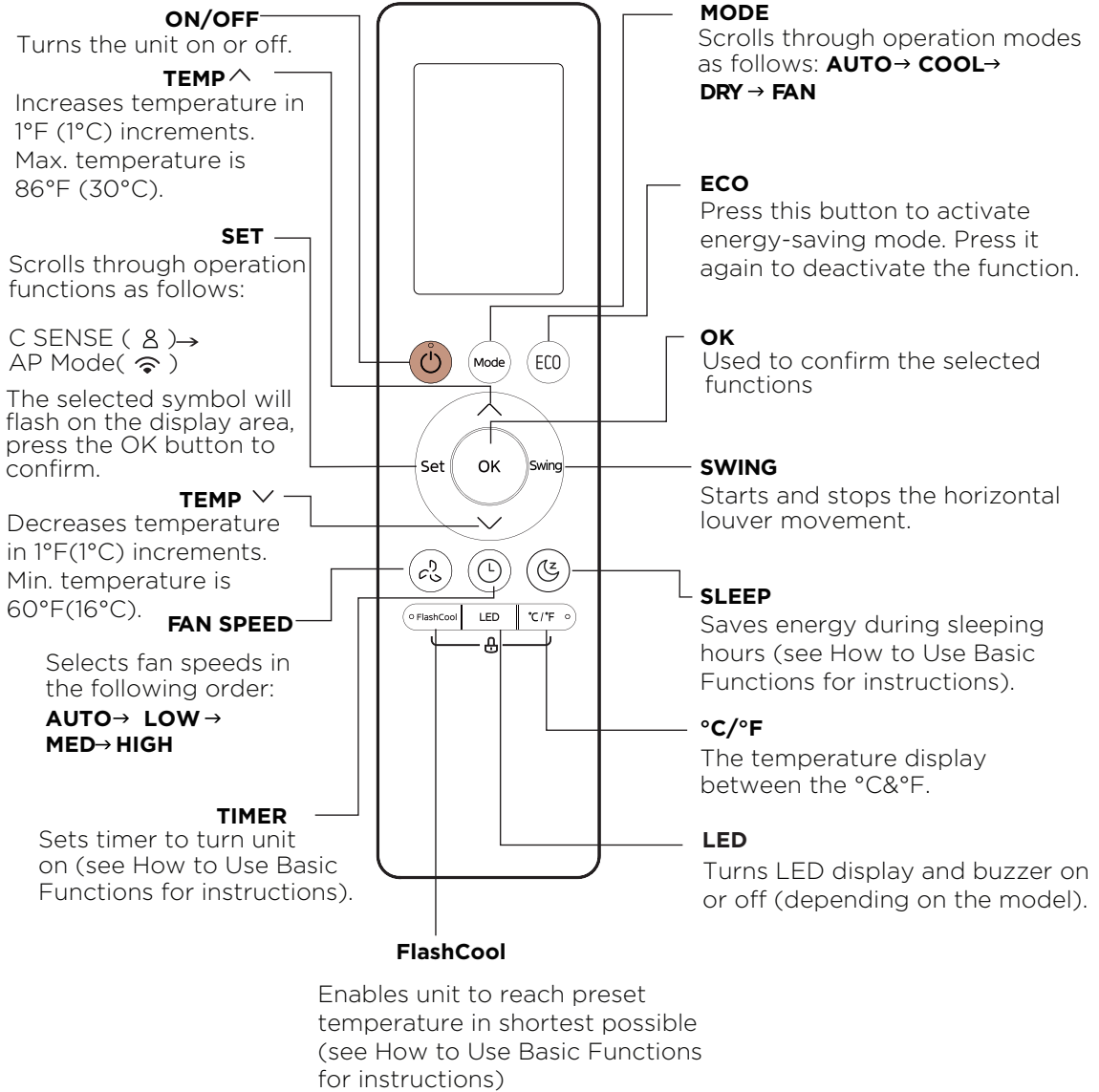

## Supplier's Declaration of Conformity 47 CFR § 2.1077 Compliance Information

**Unique Identifier:** Midea brand, RG10A16(B2S)/BGCEFU1

### Responsible Party U.S. Contact Information

Midea America Corporation  
300 Kimball Dr  
Parsippany NJ  
07054

Telephone number or internet contact information: Midea.com/us

### FCC Compliance Statement ( products subject to Part 15)

This device complies with Part 15 of the FCC Rules. Operation is subject to the following two conditions: (1) This device may not cause harmful interference, and (2) this device must accept any interference received, including interference that may cause undesired operation.

# Remote Screen Indicators

Information is displayed when the remote controller is powered on.

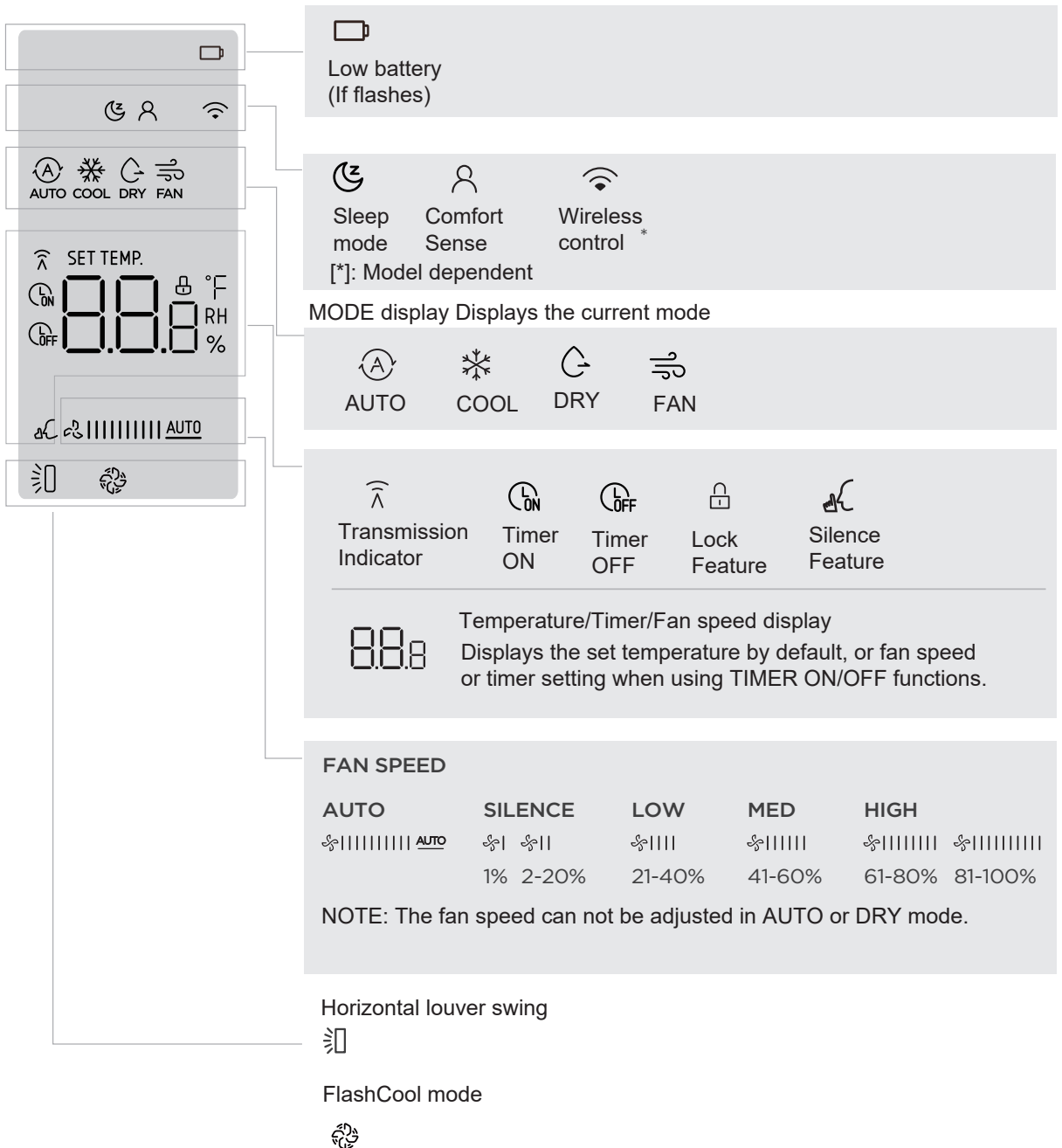

**Note:**

All indicators shown above are for information purposes. During the actual operation, only the relevant indicators will be shown on the display.

## How to Use Basic Functions

**⚠ Note :** Before operation, please ensure the unit is plugged in and power is available.

### AUTO Mode

Select AUTO mode

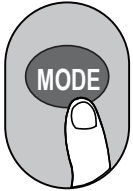

Set the temperature

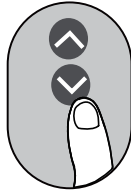

Turn on the air conditioner

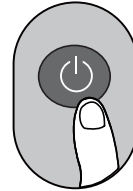

#### NOTE:

1. In AUTO mode, the unit will automatically select the COOL, FAN function based on the set temperature.
2. In AUTO mode, fan speed cannot be set.

### COOL Mode

Select COOL mode

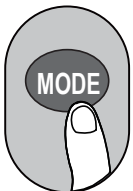

Set the temperature

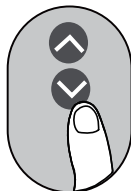

Set the fan speed



Turn on the air conditioner

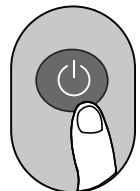

### DRY Mode

Select DRY mode

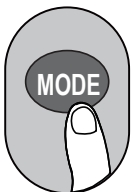

Set the temperature



Turn on the air conditioner

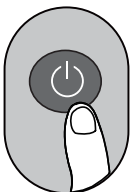

**NOTE:** In DRY mode, fan speed cannot be set since it has already been automatically controlled.

### FAN Mode

Select FAN mode

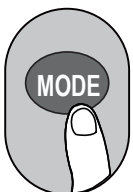

Set the fan speed

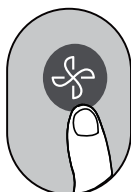

Turn on the air conditioner



**NOTE:** In FAN mode, fan speed cannot be set. As a result, no temperature displays on the remote screen.

## Setting the TIMER

**TIMER ON/OFF** - Set the amount of time after which the unit will automatically turn on/off.

### TIMER ON setting

Press **TIMER ON** button to initiate the ON sequence.

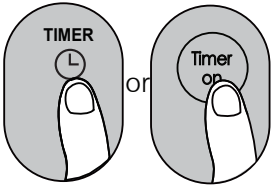

Press **up** or **down** button for multiple times to set the desired time to turn on the unit.



Point remote to unit and wait 1 second, the **TIMER ON** will be activated.



### TIMER OFF setting

Press **TIMER OFF** button to initiate the OFF time sequence.

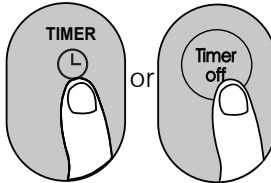

Press **Temp. up** or **Temp. down** button for multiple times to set the desired time to turn off the unit.

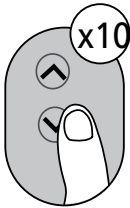

Point remote to unit and wait 1 second, the **TIMER OFF** will be activated.



### NOTE:

- When setting the **TIMER ON** or **TIMER OFF**, the time will increase by 30 minutes increments with each press, up to 10 hours. After the 10th hour, the timer increases in 1-hour increments up to 24 hours. (i.e. Pressing the button 5 times sets the timer to 2.5 hours, and pressing 10 times sets it to 5 hours. The timer will reset to 0.0 after reaching 24 hours.)
- Cancel either function by setting its timer to 0.0h.

### Example of TIMER sequence

Note that the time periods set for both functions are based on hours from the current time.

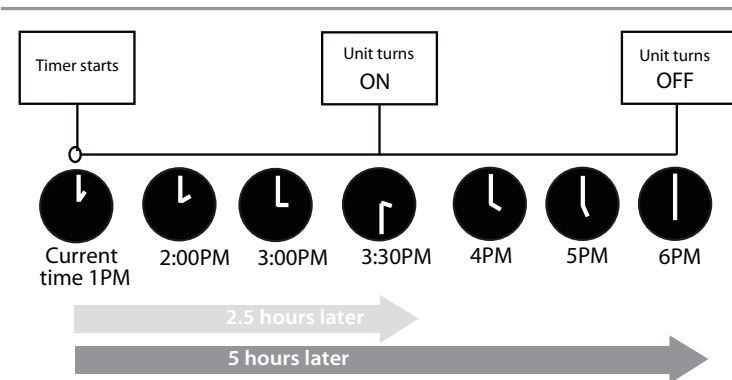
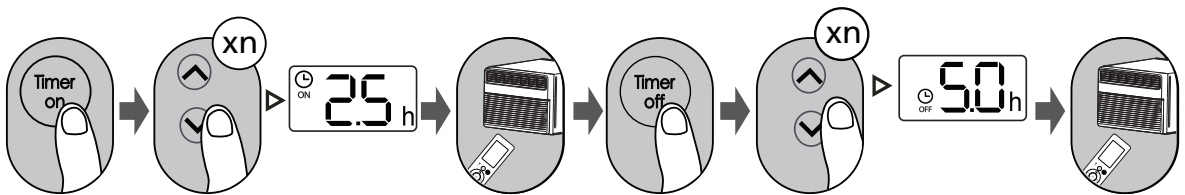

i.e. If current timer is 1:00PM, to set the timer as above steps, the unit will turn on 2.5h later (3:30PM) and turn off at 6:00PM.



## How to Use Advanced Functions

### Swing function

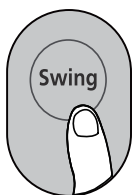

The horizontal louver will swing up and down automatically when pressing Swing button. Press again to make it stop.

### °C/°F

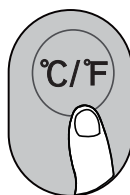

Press this button will alternate the temperature display between the °C & °F.

### ECO function



Press ECO to turn on the energy saver function. This function is available on COOL, DRY, AUTO modes.

### LED DISPLAY

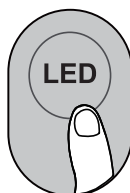

Press this button to turn on and turn off the display on the indoor unit.

## FlashCool Function

Press FlashCool button

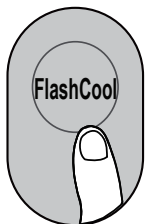

Press this button in COOL mode to activate the FlashCool function. In this mode, the unit will rapidly lower the room temperature.

## SLEEP Function



SLEEP function reduces energy usage when activated by adjusting the temperature settings.

## LOCK function

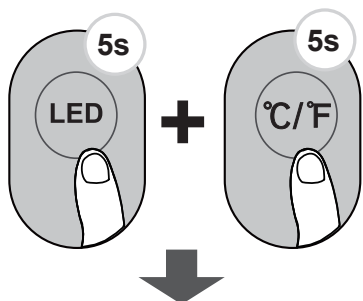

Press together LED button and °C/°F button at the same time more than 5 seconds to activate Lock function.

All buttons will be unresponsive except for these two. Press and hold them for two seconds to disable the lock function.

**Note:** The SLEEP function is not available in FAN or DRY mode.

## SET function

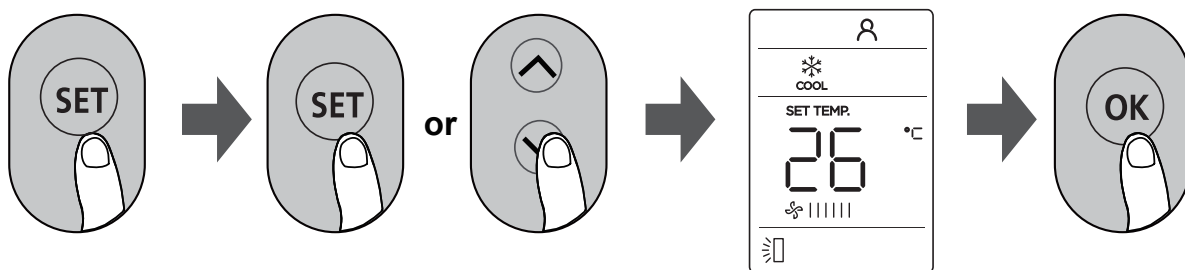

- Press the SET button to enter the function setting, then press SET button or TEMP  $\downarrow$  or TEMP  $\uparrow$  button to select the desired function. The selected symbol will flash on the display area, press the OK button to confirm.
- To cancel the selected function, please follow the same procedures outlined above.
- Press the SET button to scroll through operation functions as follows:  
Clean (🌀)\* → COMFORT SENSE (👤) → AP mode(📶)\*  
[\*]: Model dependent.

### COMFORT SENSE function (👤) :

The COMFORT SENSE function allows the remote control to measure the temperature at its location and send this data to the air conditioner every 3 minutes. In AUTO, COOL modes, using the remote control's temperature readings instead of those from the indoor unit helps optimize the temperature around the user for maximum comfort.

### AP function (📶) :

Choose AP mode to do wireless network configuration. For some units, it doesn't work by pressing the SET button. To enter the AP mode, continuously press the LED button seven times in 10 seconds.

## Declaration of Conformity

We hereby declare that this AC is in compliance with the essential requirements and other relevant provisions of Directive 1999/5/EC.

## Specification of Wireless Module

Model: US-SK109	Dimensions: 1.6 x 0.9 x 0.2 (in)
Antenna Type: Printed PCB Antenna	Operation Temperature: 0°C - 45°C / 32°F - 113°F
Frequency: WLAN 2400-2483.5 MHz	Operation Humidity: 10% - 85%
Maximum Transmitted Power: <20 dBm Max	Power Input: DC 5V/500 mA

# Matter Instructions

## 1 What is Matter

Matter is a connectivity technology that unifies the smart home by allowing devices and ecosystems (such as Alexa, Google Home and Apple Home) to speak the same language thus creating exciting new features and use cases.

Top industry brands such as Apple, Google, Amazon, Midea and others collaborated to create Matter which provides the following benefits:

- Seal of approval that smart home devices will work seamlessly together – today and tomorrow.
- Familiar and consistent process to make setup simple, reliable, and secure.
- Consistent and responsive local connectivity that still works if the internet is down.
- Extra layer of cybersecurity for peace of mind.

To use Matter, at least one Matter-enabled smart speaker or display from Amazon, Google, or Apple is required, along with the respective app for that device.

- If a Matter-enabled smart speaker and/or display is available, refer to the "How to use Matter" instructions below.
- If a Matter-enabled smart speaker and/or display is not available, Matter cannot be used at this time. Full functionality can still be achieved using the SmartHome app. For details, see the "How to use SmartHome app" section on page 37.

## 2 How to use Matter ✨

### Connect Air Conditioner through Matter

⚠️ Make sure the mobile device is connected to the correct wireless router.

Wireless router should support IPv6.

For best Matter compatibility, connect the AC to the Alexa, Google Home or Apple Home ecosystems along with at least one of their respective Matter enabled smart speakers.

#### ■ Step 1: Connect to smart speaker

Select the preferred platform (Alexa, Google Home, or Apple Home) and ensure that a Matter-enabled product (such as a smart speaker) from that platform is connected to the wireless router.

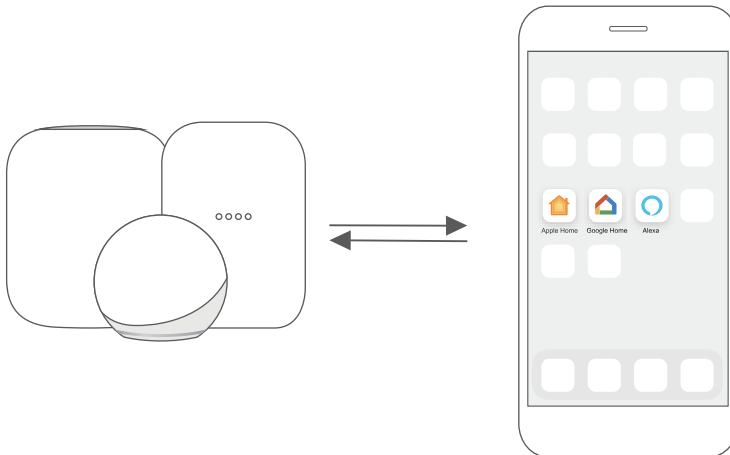

## ■ Step 2: Turn on Bluetooth

Turn on Bluetooth on the mobile device.

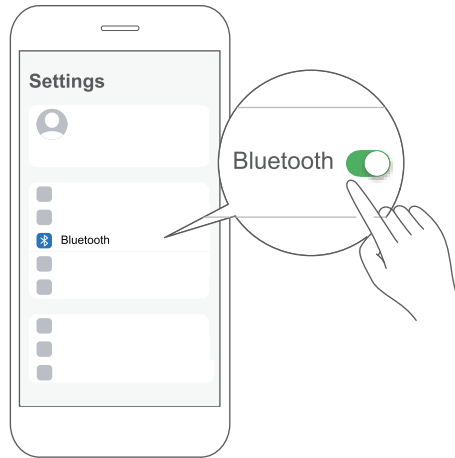

## ■ Step 3: Enter AP mode

Window AC: Hold down the CONNECT button for 3 seconds to begin the pairing process ("AP" will appear on the AC's display).

Note: Entering AP pairing mode may vary between different AC models, please follow the instructions of the AC panel.

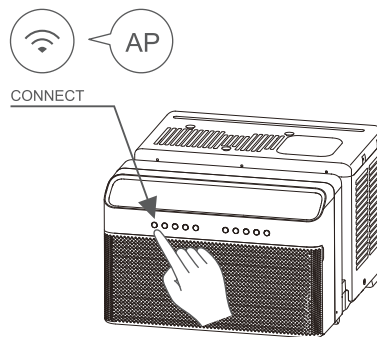

Window AC

## ■ Step 4: Open app

Open the Alexa, Google Home, Apple Home app on the mobile device.

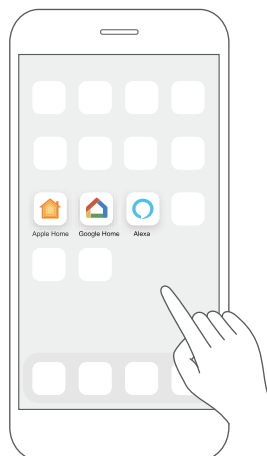

### ■ Step 5: Scan Matter QR code

Tap the "+" and "Add Device/Accessory" or tap "+Add" in the app and then select Matter device and scan the Matter QR code found on the side of the AC device. Follow the respective instructions in the Alexa, Google Home or Apple Home app to complete the pairing process.

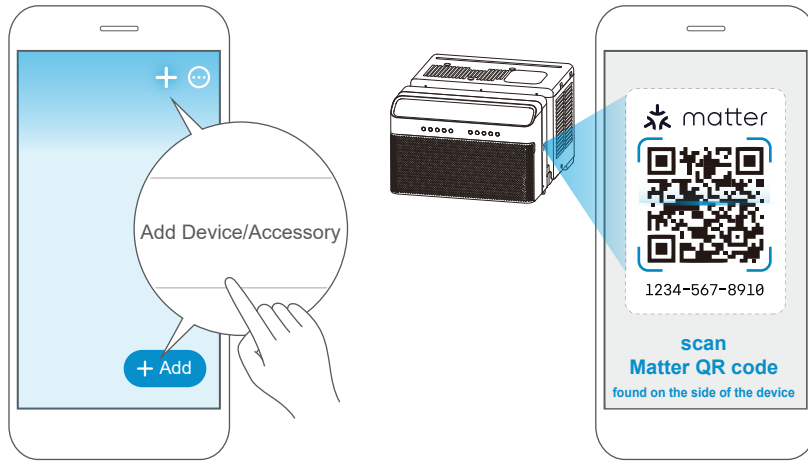

### ■ Step 6: Control device

After a successful pairing, the unit's temperature and mode settings etc. can be controlled through the respective platform app or smart speaker.

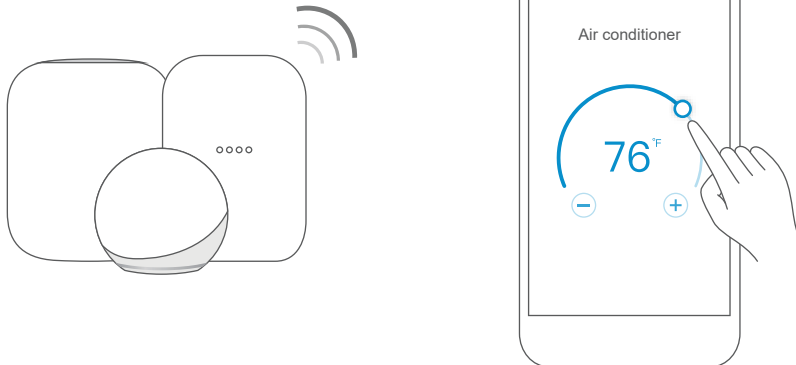

App & Smart Speakers can support Matter only when using these versions or above.

Device	Version
iPhone	iOS16.5
Apple Home Pod	16.5
Android	Google Play services min version: 22.36.15 Google Home app (GHA) min version: 2.58.24.1-dogfood
Google Home Hub	Google Hub firmware min version: 1.56.324896 (appears on hub as Chromecast firmware version)
Alexa App	2.2.536317
Alexa Echo Device	9094439556

**NOTE:**

- Setup processes and features may vary between ecosystems.
- Make sure the Matter enabled app is up to date to ensure the best experience.
- Periodically, the software will be updated to improve experience.  
Device software updates can be accomplished through the SmartHome app.



### 3 How to use SmartHome App

- △ Ensure that the mobile phone is connected to the wireless network. Bluetooth must be turned on. The device must also be powered up.

#### ■ Step 1: Download the SmartHome app

Scan the QR code below to download the SmartHome app from the app store or search for it directly on the Google Play Store or Apple's App Store.



#### ■ Step 2: Log in

Open the SmartHome app. Log in if an existing SmartHome account is available or create a new account. Alternatively, use a third-party login platform.

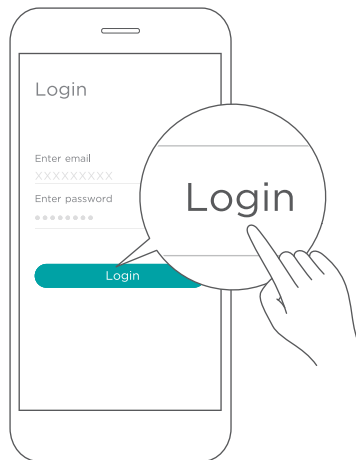

### ■ Step 3: Connecting the device

1) Upon logging in, a message stating "Smart devices discovered nearby" may appear. Tap to add the device.

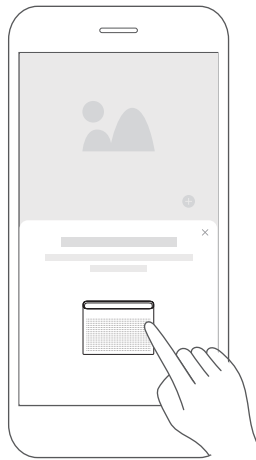

2) If the message does not appear, tap on "+" and select the device from the list of nearby available devices. If the device is not listed, add it manually by first selecting the device category, such as Window AC.

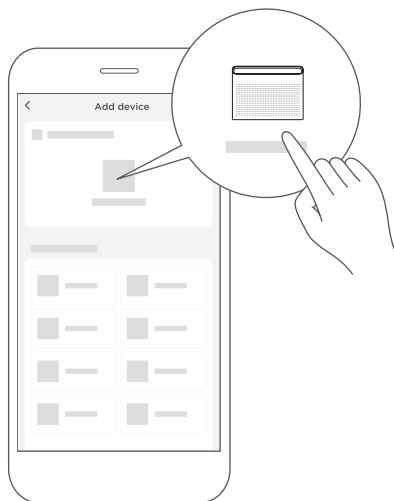

3) Follow the app's instructions to connect the device to the wireless network. If the connection fails, refer to the additional instructions provided in the app.

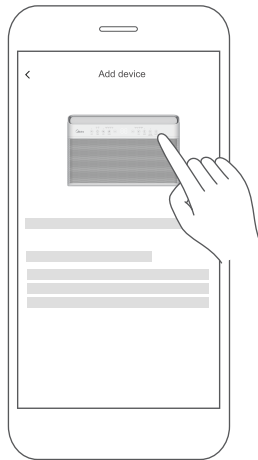

#### ■ Step 4: Controlling the device

After pairing successfully, a card will be created for the device in the SmartHome app. (Fig. 1)  
Shortcuts for basic functions will appear on the card such as changing the temperature or switching the device on or off.  
Tapping on the card, will reveal additional features and settings. The actual UI design may look different from examples due to app updates.

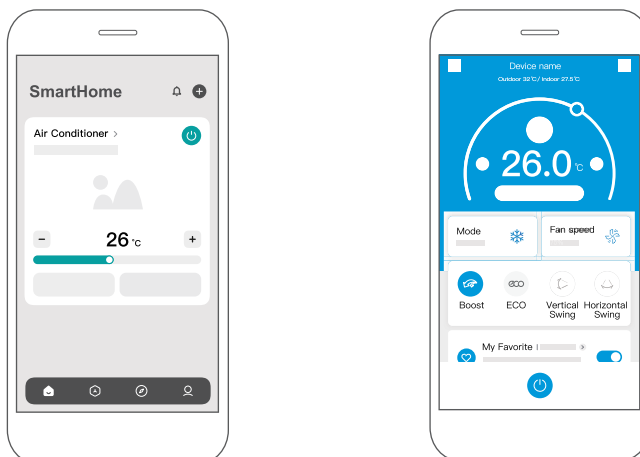

(Fig. 1)

## ■ Declaration of conformity

FCC ID: 2ADQOMDNA23

IC: 12575A-MDNA23

This device complies with Part 15 of the FCC Rules and Industry Canada's licenceexempt RSSs.

Operation is subject to the following two conditions:

(1) This device may not cause interference;

(2) This device must accept any interference, including interference that may cause undesired operation of the device.

Only operate the device in accordance with the instructions supplied.

Changes or modifications to this unit not expressly approved by the party responsible for compliance could void the user's authority to operate the equipment.

This device complies with FCC radiation exposure limits set forth for an uncontrolled environment. In order to avoid the possibility of exceeding the FCC radio frequency exposure limits, human proximity to the antenna shall not be less than 20cm (8 inches) during normal operation.

### NOTE:

This equipment has been tested and found to comply with the limits for a Class B digital device, pursuant to part 15 of the FCC Rules. These limits are designed to provide reasonable protection against harmful interference in a residential installation.

This equipment generates, uses and can radiate radio frequency energy and, if not installed and used in accordance with the instructions, may cause harmful interference to radio communications. However, there is no guarantee that interference will not occur in a particular installation. If this equipment does cause harmful interference to radio or television reception, which can be determined by turning the equipment off and on, the user is encouraged to try to correct the interference by one or more of the following measures:

--Reorient or relocate the receiving antenna.

--Increase the separation between the equipment and receiver.

--Connect the equipment into an outlet on a circuit different from that to which the receiver is connected.

--Consult the dealer or an experienced radio/TV technician for help.

We, hereby declare that this device is in compliance with the relevant provisions of RE Directive 2014/53/EU. A copy of the full DoC is attached (European Union products only).

# CLEANING AND MAINTENANCE

## CAUTION

Clean the air conditioner occasionally to keep it looking new. Be sure to unplug the unit before cleaning to prevent shock or fire hazards.

## Air Filter Cleaning

The air filter should be checked at least once every two weeks to see if cleaning is necessary. Trapped particles in the filter can build up and reduce performance by restricting airflow through the coils.

- Grasp the filter by the center and pull up and out.
- Wash the filter using warm water. Rinse filter thoroughly.
- Gently shake excess water from the filter. Be sure the filter is thoroughly dry before replacing.
- Instead of washing, the filter may also be vacuumed clean.

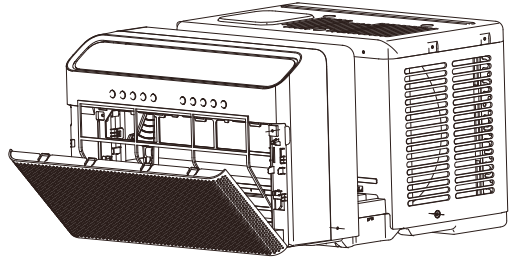

## NOTE

Never use hot water over 104°F (40°C) to clean the air filter. Never attempt to operate the unit without the air filter.

## Cabinet Cleaning

- Be sure to unplug the air conditioner to prevent shock or fire hazard. The cabinet and front may be dusted with an oil-free cloth or washed with a cloth dampened in a solution of warm water and mild liquid dishwashing detergent. Rinse thoroughly and wipe dry.
- Never use harsh cleansers, wax, or polish on the air conditioner.
- Be sure to wring excess water from the cloth before wiping around the controls. Excess water in or around the controls will cause damage to the air conditioner.
- Plug in air conditioner.

## Back Protective Net Cleaning (On some models)

- To clean the back protective net, first switch off the unit, then use a brush to clean the net and use water to wash directly.
- It is highly recommended to remove the water plug when washing the back protective net, and then insert the water plug back into the original place after draining to avoid mold or odor.

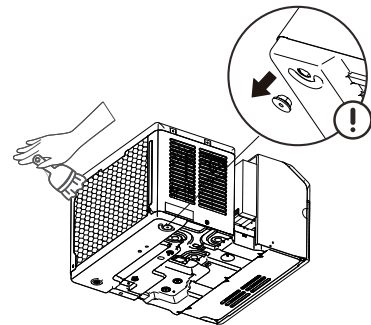

## Winter Storage

If storing the air conditioner for winter, remove it carefully from the window following the installation instructions. Avoid spilling any standing water from the unit's base pan; if water is present, drain it carefully. Cover the unit with plastic or place it back in the original carton and store in a cool, dry place.

# TROUBLESHOOTING TIPS

Before calling for service, review this list. It may save time and expense. This list includes common occurrences that are not the result of defective workmanship or materials in this unit.

Problem	Solution
Air conditioner does not start.	Wall plug disconnected. Push plug firmly into wall outlet.
	Circuit breaker tripped. Reset circuit breaker.
	Check if the light on the plug is on. If it is off, press the RESET button.
	Power is OFF. Turn power ON.
Air from unit does not feel cold enough.	Unit turned off and then on quickly. Turn unit off and wait 3 minutes before restarting.
	Room temperature below 60°F (16°C). Cooling may not occur until room temperature rises above 60°F (16°C).
	Temperature sensor behind the air filter is touching the cold coil. Try to move it so it does not contact the cold coil.
	Reset to a lower temperature.
Air conditioner cooling, but room is too warm- ice forming on cooling coil behind air filter.	Compressor shut-off by changing modes. Wait approximately 3 minutes and listen for compressor to restart when set in the COOL mode.
	Check for potential obstructions blocking the outdoor intake/exhaust. Clear any obstructions.
	Outdoor temperature below 64°F (18°C). To defrost the coil, set to FAN ONLY mode.
	Air filter may be dirty. Clean filter. Refer to Care and Cleaning section. To defrost, set to FAN ONLY mode.
Air conditioner cooling, but room is too warm- NO ice forming on cooling coil behind air filter.	Thermostat set too cold for night-time cooling. To defrost the coil, set to FAN ONLY mode. Then, set temperature to a higher setting.
	Dirty or restricted air filter. Clean filter. Refer to Care and Cleaning section. To defrost, set to FAN ONLY mode.
	Temperature is set too high, set temperature to a lower setting.
	Air directional louvers positioned improperly. Position louvers for better air distribution.
Air conditioner cooling, but room is too warm- NO ice forming on cooling coil behind air filter.	Front of unit is blocked by drapes, blinds, furniture, etc. - restricts air distribution. Clear obstruction in front of unit.
	Any open doors, windows, or vents may allow cold air to escape. Close any doors, windows, or vents.
	The room may be too warm. Allow additional time to remove "stored heat" from walls, ceiling, floor and furniture.

Problem	Solution
Air conditioner turns on and off rapidly.	Dirty air filter- air restricted. Clean air filter.
	Outside temperature extremely hot. Set FAN speed to a higher setting to bring air past cooling coils more frequently.
	Check for potential obstructions blocking the outdoor intake/exhaust. Clear any obstructions.
Noise when unit is cooling.	Air movement sound. This is normal. If too loud, set to a slower FAN setting.
	Window vibration - poor installation. Refer to installation instructions or check with installer.
Water dripping INSIDE when unit is cooling.	Improper installation. Tilt air conditioner slightly to the outside to allow water drainage. Refer to installation instructions - check with installer.
Water dripping OUTSIDE when unit is cooling.	Unit removing large quantity of moisture from humid room. This is normal during excessively humid days.
Remote sensing deactivating prematurely (some models).	Remote control not located within range. Place remote control within 26 feet & 180°, radius of the front of the unit, and pointed in the general direction of the air conditioner unit.
	Remote control signal obstructed. Remove obstruction.
Room too cold.	Temperature setting too low. Increase temperature setting.
Noise when unit starts.	A 30 second high pitched noise may occur when the unit is turned on due to the compressor starting. This is normal.
Window does not insert into the U-shaped slot.	Ensure that the "U-shaped" slot is in line with the window, if not, align the slot with the window. Ensure that the unit is not slanted too much to cause interference with the top of the unit. Reference the installation instructions for more information.
Unit will not connect to WiFi or App does not work (some models).	For additional support and troubleshooting tips, visit the "Help" tab within the SmartHome app.

# TRADEMARKS, COPYRIGHTS AND LEGAL STATEMENT

 Midea logo, word marks, trade name, trade dress and all versions thereof are valuable assets of Midea Group and/or its affiliates (“Midea”), to which Midea owns trademarks, copyrights and other intellectual property rights, and all goodwill derived from using any part of a Midea trademark. Use of Midea trademark for commercial purposes without the prior written consent of Midea may constitute trademark infringement or unfair competition in violation of relevant laws.

This manual is created by Midea and Midea reserves all copyrights thereof. No entity or individual may use, duplicate, modify, distribute in whole or in part this manual, or bundle or sell with other products without the prior written consent of Midea.

All the described functions and instructions were up to date at the time of printing this manual. However, the actual product may vary due to improved functions and designs.



# DATA PROTECTION NOTICE

For the provision of the services agreed with the customer, we agree to comply without restriction with all stipulations of applicable data protection law, in line with agreed countries within which services to the customer will be delivered, as well as, where applicable, the EU General Data Protection Regulation (GDPR).

Generally, our data processing is to fulfill our obligation under contract with you and for product safety reasons, to safeguard your rights in connection with warranty and product registration questions. In some cases, but only if appropriate data protection is ensured, personal data might be transferred to recipients located outside of the European Economic Area.

Further information are provided on request. You can contact our Data Protection Officer via **MideaDPO@midea.com**. To exercise your rights such as right to object your personal data being processed for direct marketing purposes, please contact us via **MideaDPO@midea.com**. To find further information, please follow the QR Code.

The design and specifications are subject to change without prior notice for product improvement. Consult with the sales agency or manufacturer for details. Any updates to the manual will be uploaded to the service website, please check for the latest version.

# WARRANTY

## Air Conditioner Limited Warranty

Your product is protected by this Limited Warranty:

Warranty service must be obtained from Midea Consumer Services or an authorized Midea servicer.

---

### Warranty

- One Year Limited Warranty from the date of delivery or the purchase date, whichever is later.
- Five Year Limited Sealed System Warranty (includes components containing refrigerant) from the date of delivery or the purchase date, whichever is later.
- Three Year Limited Compressor Warranty from the date of delivery or the purchase date, whichever is later.
- The date of delivery establishes the warranty period, should service be required.

### Midea, through its authorized servicers will:

- Pay all costs for repairing or replacing parts of this unit which prove to be defective in materials or workmanship.

### Consumer will be responsible for:

- Diagnostics, removal, transportation and reinstallation cost required because of service.
- Costs of service calls that are a result of items listed under NORMAL RESPONSABILITIES OF THE CONSUMER\*\*

Midea replacement parts shall be used and will be warranted only for the original warranty.

---

### NORMAL RESPONSIBILITIES OF THE CONSUMER\*\*

**This warranty applies only to products in ordinary household use, and the consumer is responsible for the items listed below:**

1. Proper use of the unit in accordance with instructions provided with the product.
2. Routine maintenance and cleaning necessary to keep the good working condition.
3. Proper installation by an authorized service professional in accordance with instructions provided with the unit and in accordance with all local plumbing, electrical and/or gas codes.
4. Proper connection to a grounded power supply of sufficient voltage, replacement of blown fuses, repair of loosen connections or defects in house wiring.
5. Expenses for making the unit accessible for servicing.
6. Damages to finish after installation.

### EXCLUSIONS

**This warranty does not cover the following:**

- 1) Failure caused by damage to the unit while in your possession (other than damage caused by defect or malfunction), by its improper installation, or by unreasonable use of the unit, including without limitation, failure to provide reasonable and necessary maintenance or to follow the written installation and Operating Instructions.
- 2) Damages caused by serviced performed by persons other than those authorized by Midea customer service; or external causes such as abuse, misuse, inadequate power supply or acts of God.
- 3) If the unit is put to commercial, business, rental, or other use or application other than for consumer use, we make no warranties, express or implied, including but not limited to, any implied warranty of merchantability or fitness for use or purpose.
- 4) Products without original serial numbers or products that have serial numbers which have been altered or cannot be readily determined.

**NOTICE: Some states do not allow the exclusions or limitation of incidental or consequential damages. So this limitation or exclusion may not apply to you.**

### IF YOU NEED SERVICE

Keep the bill of sale, delivery slip, or some other appropriate payment record.

The date on the bill establishes the warranty period, should service be required.

If service is performed, its your best interest to obtain and keep all receipts.

This written warranty provides specific legal rights, and additional rights may vary by state.

Service under this warranty must be obtained by following these steps, in order:

- 1) Contact Midea Consumer Services or an authorized Midea services at 1 866 646 4332.
- 2) If there is a question as to where to obtain service, contact our consumer relations Department.





*make yourself at home*



[www.midea.com](http://www.midea.com)

© Midea 2024 all rights reserved

CW009UI-QB

16120300A34192

20241012