

Refrigerator  
**FRENCH DOOR SERIES**

# **USER MANUAL**

**MRQ23B4AST**

Warning notices: Before using this product, please read this manual carefully and keep it for future reference. The design and specifications are subject to change without prior notice for product improvement. Consult with your dealer or manufacturer for details. The diagram above is just for reference. Please take the appearance of the actual product as the standard.



## THANK YOU LETTER

Thank you for choosing Midea! Before using your new Midea product, please read this manual thoroughly to ensure that you know how to operate the features and functions that your new appliance offers in a safe way.

# CONTENTS

THANK YOU LETTER	03
SPECIFICATIONS	04
PRODUCT OVERVIEW	05
PRODUCT INSTALLATION	06
OPERATION INSTRUCTIONS	12
CLEANING AND MAINTENANCE	16
TROUBLESHOOTING	18

# SPECIFICATIONS

<b>Product model</b>	<b>MRQ23B4AST</b>
Volume	22.5 cu.ft.(636 L)
Rated Voltage	115 V-
Rated Frequency	60 Hz
Rated Current	2.5 A
Rated Defrost Power	190 W
Refrigerant	R600a
Amount	2.68 oz (76 g)
Product Dimension ( W x D x H)	35.8x29.0x69.9 in(910 x 737 x 1775 mm)

# PRODUCT OVERVIEW

## Names of components

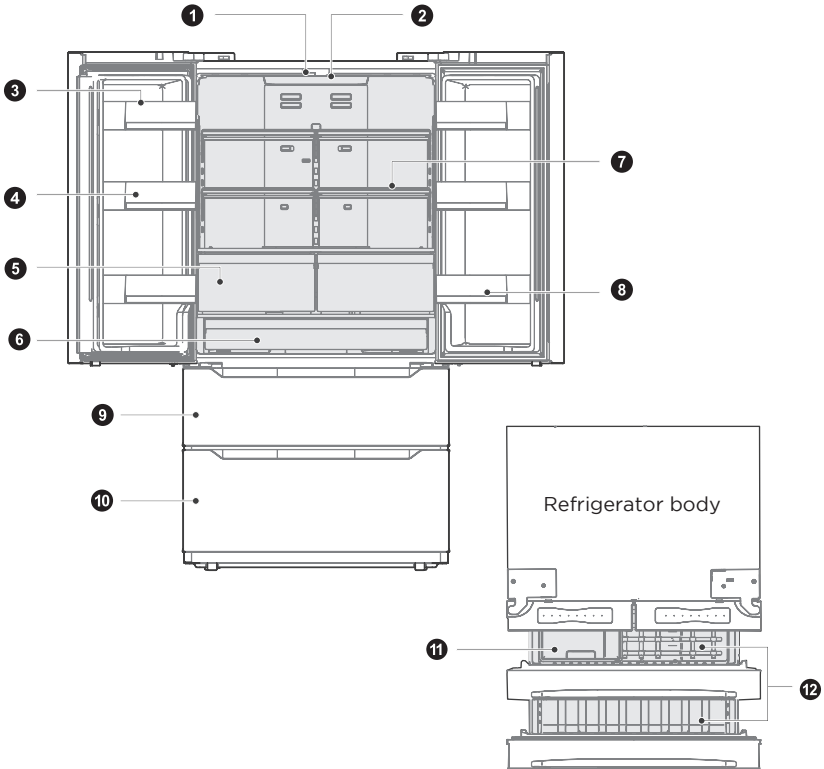

- |   |                           |    |                      |
|---|---------------------------|----|----------------------|
| 1 | LED light                 | 7  | Shelf                |
| 2 | Control and display panel | 8  | Door tray            |
| 3 | Dairy bin                 | 9  | Upper freezer drawer |
| 4 | Door tray                 | 10 | Lower freezer drawer |
| 5 | Crisper drawer            | 11 | Ice storage bin      |
| 6 | Big drawer                | 12 | Freezer drawer       |

### ATTENTION

The picture above is only for reference. The actual configuration will depend on the physical product or statement by the distributor

# PRODUCT INSTALLATION

## Install Instruction

### Finding a suitable location

- This refrigerator is designed to be free standing only, and should not be recessed or built-in.
- The refrigerator should be placed in a well-ventilated indoor place; the ground shall be flat and sturdy .
- Keep away from heat and avoid direct sunlight. Do not place the refrigerator in moist or watery places to prevent rust or reduction of insulating effect.

### Dimensions and Clearances

- Too small of a distance from adjacent items may result in the degradation of freezing capability and increased electricity costs. the refrigerator both sides should be placed against the wall with a free distance more than 100mm, and the refrigerator back against the wall distance not more than 75 mm.

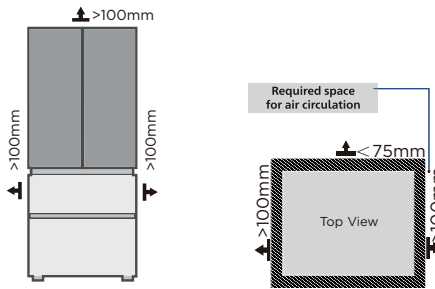

### Providing a proper power supply

- Check your local power source. This refrigerator requires a **AC115 V, 60 Hz** power supply.
- Use a receptacle that accepts the grounding prong. The power cord is equipped with a 3-prong (grounding) plug which mates with a standard 3-prong (grounding) wall outlet to minimize the possibility of electric shock hazard from this refrigerator.



## CAUTION

The refrigerator should always be plugged into its own individual electrical outlet which has a voltage rating that matches the rating plate.

Never unplug your refrigerator by pulling on the power cord. Always grip the plug firmly and pull straight out from the outlet.

## Start to use

- The refrigerator shall stay for half an hour before connecting power when it is firstly started.
- The refrigerator shall run 2 to 3 hours before loading fresh or frozen foods; the refrigerator shall run for more than 4 hours in summer in advance considering that the ambient temperature is high.

Space requirement diagram (when the door is open and when the door is closed)

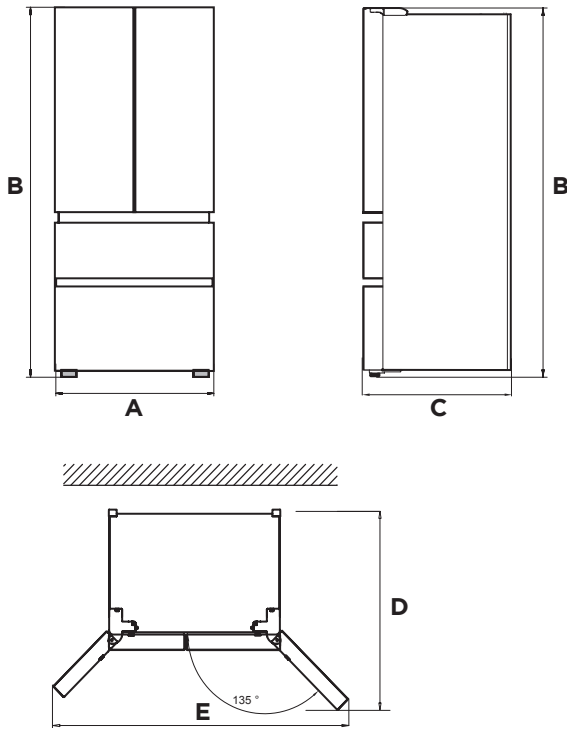

Width	Overall Height	Depth	Depth doors open 135°	Width doors open 135°
A	B	C	D	E
910	1775	737	1047	1600

Notice: All dimensions in mm

**ATTENTION**

The picture above is only for reference. The actual configuration will depend on the physical product or statement by the distributor.

## Installing the Water Line

### Installing the Water Line

- Water line installation kits are available as an additional accessory from your dealer or at a local hardware store.
- First, shut off the main water supply line and turn the ice-maker off.
  - Locate the nearest cold water supply valve.
  - After connecting the water supply to the water valve, turn your main water supply back on and flush several gallons of water to clear the water supply line.

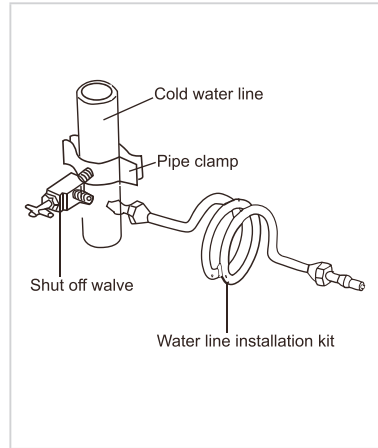

### Connecting the Water Line to The Refrigerator

- There are several items that you need to purchase to complete this connection.
  - You will find these items sold as a kit at your local hardware store.
- First, water tubes (supplied) insert into corresponding hole of water connector (supplied).
  - Second, water line installation kit (not included) inserts into another hole of water connector (supplied).
  - Turn water valve on and check for any leakage.

### Connecting the Water Line to A Drinkable Water Source

- If your water line is not drinkable, please add an external water filter.
- If you must repair or disassemble the water line, cut off the plastic tubing to make sure you get a snug, leak-free connection.

#### ATTENTION

The minimum inlet water pressure: 276kPa.  
The maximum inlet water pressure: 689kPa.  
**WARNING:** Connect to potable water supply only. New hose-sets supplied with the appliance are to be used and that old hosesets should not be reused.

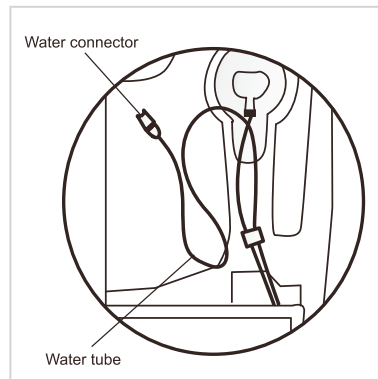



## Door handle installation

- Please take precautions to secure the handle and prevent injury.

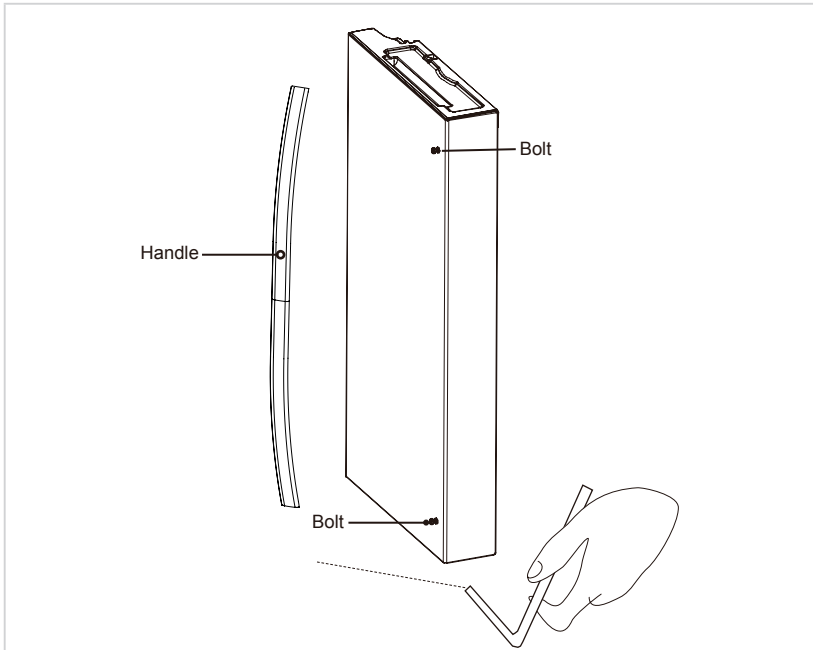

### Step

1. First take out the bolts for fixing the handle from the package bag of the user manual and then fasten it on the door body with a cross screwdriver.
2. Take out the door handle from the refrigerating chamber after the first step is completed, and then place it the door in the direction as on shown in the figure and make the two bolts for fixing the handle in the handle.
3. Use the allen wrench to fasten the screws in two holes of each handle with the handle fixing bolts.



## Leveling feet

To avoid vibration, the unit must be leveled.

If required, adjust the leveling screws to compensate for the uneven floor.

The front should be slightly higher than the rear to aid in door closing.

Leveling screws can be turned easily by tipping the cabinet slightly.

Turn the leveling screws counterclockwise  to raise the unit, clockwise  to lower it.

## Leveling doors

### List of tools to be provided by the user



Pliers

1. Raise the lower door up to the level of the higher door.
2. Insert the supplied fastener-ring by using plier in the gap between the hinge-grommet and the lower hinge. The number of fastener-rings you will need to insert depends on the gap.

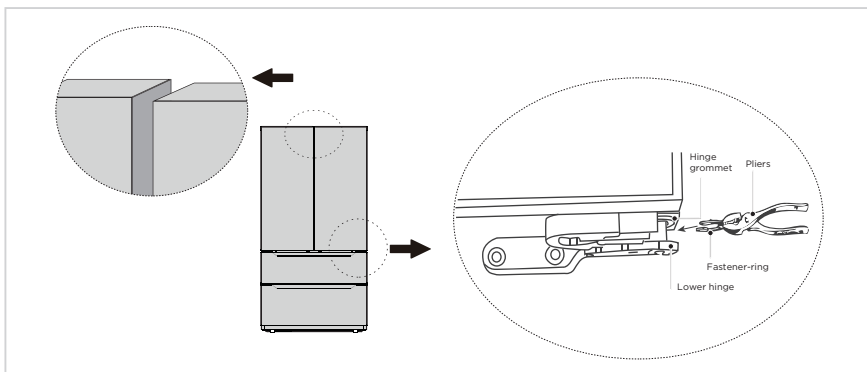

## Moving the appliance

1. Remove all food from inside the appliance.
2. Pull the power plug out, insert and fix it into the power plug hook at the rear or on top of the appliance.
3. Tape parts such as shelves and the door handle to prevent from falling off while moving the appliance.
4. Move the appliance with more than two people carefully. When transporting the appliance over a long distance, keep the appliance upright.
5. After installing the appliance, connect the power plug into a socket out to switch on the appliance.

## Changing the light

- Any replacement or maintenance of the LED lamps is intended to be made by the manufacturer, its service agent or similar qualified person.

## Connecting the appliance

After installing the appliance, connect the power plug into a socket outlet.

### ATTENTION

- After connecting the power supply cord (or plug) to the outlet, wait 2 or 3 hours before you put food into the appliance. If you add food before the appliance has cooled completely, your food may spoil.

#### Precautions before operation:

- Before making changes the refrigerator must be disconnected from power.
- precautions should be taken to prevent any personal injury.

## Tips for energy saving

- Do not place the appliance near cookers, radiators or other heat sources. If the ambient temperature is high, the compressor will run more frequently and for longer, resulting in increased energy consumption.
- Ensure that there is sufficient ventilation at the base of the appliance, on the sides of the appliance and at the back of the appliance. Never cover ventilation openings.
- Please also observe the spacing dimensions in the chapter „Installation“.
- The arrangement of drawers, shelves and racks as shown in the illustration offers the most efficient use of energy and should therefore be retained as far as possible. All drawers and shelves should remain in the appliance to keep the temperature stable and save energy.
- To obtain a larger storage space (e.g. for large refrigerated/frozen goods), the middle drawers can be removed. The top and bottom drawers and shelves should be removed last if necessary.
- An evenly filled refrigerator/freezer compartment contributes to optimal energy use. Therefore, avoid empty or half-empty compartments.
- Allow warm food to cool before placing it in the refrigerator/freezer. Food that has already cooled down increases energy efficiency.
- Allow frozen food to defrost in the refrigerator. The coldness of the frozen food reduces the energy consumption in the refrigerator compartment and thus increases the energy efficiency.
- Open the door only as briefly as necessary to minimise cold loss. Opening the door briefly and closing it properly reduces energy consumption.
- The door seals of your appliance must be perfectly intact so that the doors close properly and energy consumption is not increased unnecessarily.

# OPERATION INSTRUCTIONS

## Control panel



Buttons			
1	Ice-making button	4	Temperature adjusting button of freezer room
2	Super cool button	5	Super freeze button
3	Temperature adjusting button of refrigerator room	6	Lock/unlock button

## Display

1. When electrify the refrigerator, the display screen will totally display for 3 seconds, meanwhile the starting up bell rings ,then the display screen enters the normal display of operation.(if power-on for first time, the default set temperature of the refrigerator room and the freezer room is 41 °F / 0 °F ).
2. It will display the set temperature of both refrigerator and freezer rooms when there is no fault.
3. Under normal circumstances, the display light will go out after 30 seconds in lock state, button operation on display panel would wake up the display screen; if the opening door action wakes up the display screen, the display light would go out immediately when the door is closed; when the “fault code visible” type of fault occurs, the display screen lights up, and will go out after 30 seconds.

### ATTENTION

The actual control panel may differ from model to model.

## Operating instructions

### Lock/Unlock

1. In the unlock state, press and hold the lock/unlock button for 3 seconds to enter the lock state, and the buzzer sound rings.
2. In the lock state, press and hold the lock button for 3 seconds to enter the unlock state and the buzzer sound rings.
3. It will enter the lock state if there is no opening door action or any buttons operation within 30 seconds.
4. The alarm sound can be stopped by pressing any one button in lock state, but all other button operations need to be performed in unlock state. If you operate in the lock state, an error beep will be given.

### Refrigerator temperature setting

- Click the temperature adjusting button of refrigerator room to change the set temperature of refrigerator room, Each time click the button, the set temperature will drop 1°F. when the set temperature reaches the 34°F, click the button again, the set temperature will switch to 44°F. The temperature setting will take effect after the display panel is locked.

### Freezer temperature setting

- Click the temperature adjusting button of freezer room to change the set temperature of freezer room, Each time click the button, the set temperature will drop 1°F. when the set temperature reaches the -7°F, click the button again, the set temperature will switch to 7°F. The temperature setting will take effect after the display panel is locked.

### Switching between Fahrenheit and Celsius

- By pressing “**FRIDGE**” and “**FREEZER**” for 3 seconds, Fahrenheit and Celsius conversion can be achieved, and the corresponding icon “°C” and “°F” will be on. This setting takes effect after the display panel is locked.

### Mode setting

- Press the “**SUPER COOL**” button to start the super cool function. The refrigerator room is set at 34°F automatically, and the “**SUPER COOL**” icon shines. When exit the super cool mode, the set temperature of refrigerator room will go back to the set temperature before super cool mode.
- Press the “**SUPER FRZ**” button to start the super freeze function. The freezer room is set at -7°F automatically, and the “**SUPER FRZ**” icon shines. When exit the super freeze mode, the set temperature of freezer room will go back to the set temperature before super freeze mode.
- Press the “**ICE MAKER**” button, the ice-making function could be switched between on/off. When the “” icon is on, it indicates that the ice-making function is activated.

### Fault indication

- When the following tips to appear on the display screen, it indicates a problem with the refrigerator. Although the refrigerator in the following fault case can still provide cool/freeze functions, but the user should contact maintenance personnel, ensure the normal use of refrigerator.

Fault Code	Fault Description
E1	Temperature sensor failure of refrigerator room
E2	Temperature sensor failure of freezer room
E5	Defrost sensor error of freezer room
E6	Communication error
E7	Ambient temperature sensor error
EH	Humidity sensor error
EO	Ice maker error
EE	Ice maker sensor fault
EP	Failure of separating ice

### ATTENTION

The quick-freezing function is designed to maintain the nutritional value of the food in the freezer. It can freeze the food in the shortest time. If a large amount of food is frozen at one time, it is recommended that the user turn on the quick-freezing function and put the food in. At this time, the freezing speed of the freezer compartment is increased, which can quickly freeze the food, effectively lock the nutrition of the food, and facilitate storage.

## Tips on storing food

### Freezer compartment

- The freezer is designated for the storage of food frozen at very low temperature, long-term storage of frozen food, and for the production of ice.
- Only use the shelves in the door of the freezer to store frozen food, not for storing hot food designated for freezing.
- Do not put fresh and frozen food next to each other. The frozen food may thaw.
- When freezing fresh food (such as meat, fish or chopped meat), cut them into parts that can be used at the same time.
- Storing frozen food: instructions are usually stated on the packages, which must be followed. If there is no information on the packaging, food should not be stored for longer than three months from the date of purchase.
- When purchasing frozen food, make sure that it was frozen at a suitable temperature and that the packaging is not damaged.
- Frozen food should be kept in suitable packages to retain the quality and should be returned to the freezer compartment as soon as possible.
- If a package of frozen food shows moisture or abnormal bulging, it is probable that it was stored at the wrong temperature and the content is spoiled.
- The storage period for frozen food depends on the room temperature, the thermostat setting, the frequency of opening the door of the freezer, the type of food and the time of transporting the product from the shop to the household. Always follow the instructions printed on the packaging and never exceed the maximum storage time stated on the package.

### Cooling compartment

- To reduce moisture and subsequent ice build-up, never put liquid into the refrigerator in unsealed containers. Frost tends to concentrate in the coolest parts of the evaporator. Storing uncovered liquids results in a more frequent need for defrosting.
- Never put warm foods in the refrigerator. These should first cool down at room temperature and then be placed so as to ensure adequate air circulation in the refrigerator.
- Foods or food containers should not touch the back wall of the refrigerator because they could freeze to the wall. Do not keep regularly opening the door of the refrigerator.
- Meat and clean fish (packed in a package or plastic foil) can be placed in the refrigerator, which can be used in 1-2 days.
- Fruit and vegetables without packaging can be placed in the part designated for fresh fruit and vegetables.

### Recommended Temperature

The optimal temperature setting for food storage:

- Fridge: 4 °C , Freezer: -18 °C

### ATTENTION

The optimal temperature setting of each compartment depends on the ambient temperature. Above optimal temperature is based on the ambient temperature of 25 °C.

# CLEANING AND MAINTENANCE

## Defrosting

- The refrigerator is made based on the air-cooling principle and thus has automatic defrosting function. Frost formed due to change of season or temperature may also be manually removed by disconnection of the appliance from power supply or by wiping with a dry towel.

## Cleaning of door tray

- According to the direction arrow in the figure below, use both hands to squeeze the tray, and push it upward, then you can take it out.
- After washing the tray having been taken out, you can adjust its installing height in accordance with your requirement.

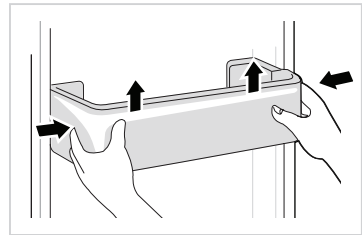

## Cleaning of glass shelf

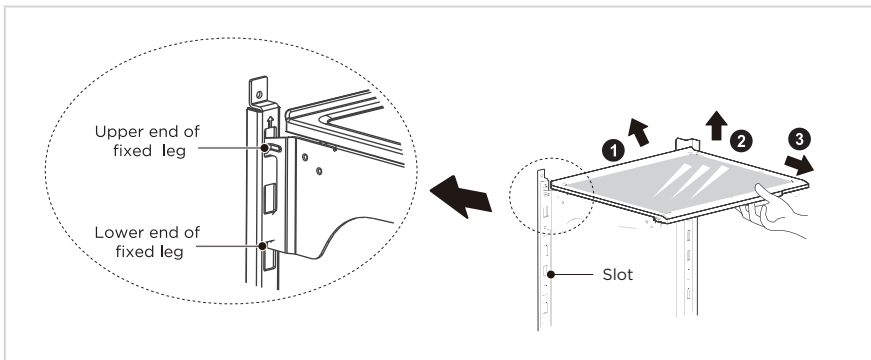

Please dismantle the cantilever shelf according to the arrows shown as above :

1. Please hold the front edge of shelf, and tilt the shelf inwards until the lower end of fixed leg is separated from the slot of supporting iron;
2. Uplift the whole shelf until it can not rise anymore;
3. Take out the shelf horizontally.

During installation, put the upper end of the fixed leg into one of the upper slots on the supporting iron first and then put the lower end of the fixed leg into the third slot on the lower part of the supporting iron.



## Cleaning of freezer lower drawer

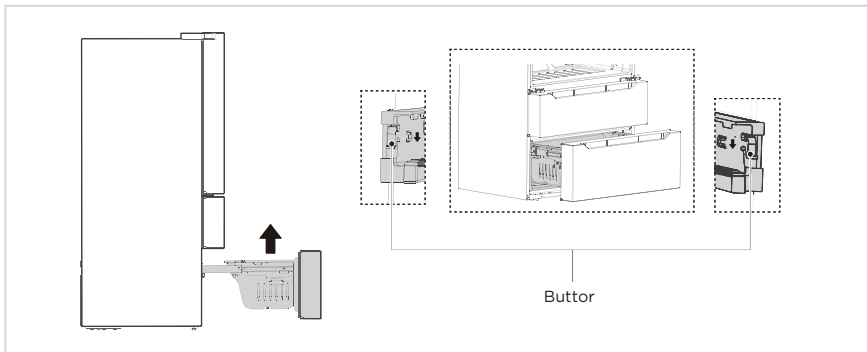

- Pull out the lower freezer drawer to the proper position.
- As shown in the Fig., press the buttons in both slots respectively (must press both sides at the same time), pull out the freezer drawer until it stops.
- Take out the lower drawer as directed by the arrows.
- After cleaning, put back the drawer to original position, then close the lower drawer, the button will lock the drawer automatically.

### ● ATTENTION

Note: Don't remove the lower freezer drawer if not necessary.

## Stop using

Power failure:

In case of power failure, even if it is in summer, foods inside the appliance can be kept for several hours; during the power failure, the times of door opening shall be reduced, and no more fresh food shall be put into the appliance.

Long-time nonuse:

The appliance shall be unplugged and then cleaned; then the doors are left open to prevent odor.

Moving:

Before the refrigerator is moved, take all objects inside out, fix the glass partitions, vegetable holder, freezing chamber drawers and etc. with tape, and tighten the leveling feet; close the doors and seal them with tape. During moving, the appliance shall not be laid upside down or horizontally, or be vibrated; the inclination during movement shall be no more than 45°.

### ● ATTENTION

The appliance shall run continuously once it is started. Generally, the operation of the appliance shall not be interrupted; otherwise the service life may be impaired. Foods can be preserved for a couple of hours even in summer in case of power failure; it is recommended to reduce the frequency of opening door.

# TROUBLESHOOTING

The following simple issues can be handled by the user. Please call the after-sale service department if the issues are not solved.

Problem	Possible reason
Failed operation	<ul style="list-style-type: none"> <li>• Check whether the appliance is connected to power or whether the plug is in well contact</li> </ul>
	<ul style="list-style-type: none"> <li>• Check whether the voltage is too low</li> </ul>
	<ul style="list-style-type: none"> <li>• Check whether there is a power failure or partial circuits have tripped</li> </ul>
Odor	<ul style="list-style-type: none"> <li>• Odorous foods shall be tightly wrapped</li> </ul>
	<ul style="list-style-type: none"> <li>• Check whether there is any rotten food</li> </ul>
	<ul style="list-style-type: none"> <li>• Clean the inside of the refrigerator</li> </ul>
Long-time operation of the compressor	<ul style="list-style-type: none"> <li>• Long operation of the refrigerator is normal in summer</li> </ul>
	<ul style="list-style-type: none"> <li>• when the ambient temperature is high It is not suggestible having too much food in the appliance at the same time</li> </ul>
	<ul style="list-style-type: none"> <li>• Food shall get cool before being put into the appliance</li> </ul>
	<ul style="list-style-type: none"> <li>• The doors are opened too frequently</li> </ul>
Light fails to get lit	<ul style="list-style-type: none"> <li>• Check whether the refrigerator is connected to power supply and whether the illuminating light is damaged</li> </ul>
	<ul style="list-style-type: none"> <li>• Have the light replaced by a specialist</li> </ul>
Door can not be properly closed	<ul style="list-style-type: none"> <li>• The door is stuck by food packages Too much food is placed</li> </ul>
	<ul style="list-style-type: none"> <li>• The refrigerator is tiltedr.</li> </ul>
Loud noises	<ul style="list-style-type: none"> <li>• Check whether the floor is level and whether the refrigerator is placed stably</li> </ul>
	<ul style="list-style-type: none"> <li>• Check whether accessories are placed at proper locations</li> </ul>

Problem	Possible reason
Door seal fails to be tight	<ul style="list-style-type: none"> <li>• Remove foreign matters on the door seal</li> </ul>
	<ul style="list-style-type: none"> <li>• Heat the door seal and then cool it for restoration (or blow it with an electrical drier or use a hot towel for heating)</li> </ul>
Water pan overflows	<ul style="list-style-type: none"> <li>• There is too much food in the chamber or food stored contains too much water,resulting in heavy defrosting</li> </ul>
	<ul style="list-style-type: none"> <li>• The doors are not closed properly, resulting in frosting due to entry of air and increased water due to defrosting</li> </ul>
Hot housing	<ul style="list-style-type: none"> <li>• Heat dissipation of the built-in condenser via the housing, which is normal When housing becomes hot due to high ambient temperature, storage of too much food or shutdown of the compressor is shut down, provide sound ventilation to facilitate heat dissipation</li> </ul>
Surface condensation	<ul style="list-style-type: none"> <li>• Condensation on the exterior surface and door seals of the refrigerator is normal when the ambient humidity is too high. Just wipe the condensate with a clean towel.</li> </ul>
Abnormal noise	<ul style="list-style-type: none"> <li>• Buzz: The compressor may produce buzzes during operation, and the buzzes are loud particularly upon start or stop. This is normal.</li> </ul>
	<ul style="list-style-type: none"> <li>• Creak: Refrigerant flowing inside of the appliance may produce creak, which is normal.</li> </ul>

## 2 YEAR LIMITED WARRANTY

This warranty is provided to the original purchaser at retail (the “Purchaser” or “you”) by Midea America Corp. (“Midea” or “we”), which warrants all parts of this Product, as described below. Midea warrants this Product to the Purchaser for personal, family or household use. This warranty covers performance and quality issues in materials and workmanship that appear under normal use and maintenance appearing within two years from the date of delivery. This warranty gives you specific rights, and you may also have other rights that vary from state to state.

### WARRANTY LIMITATIONS

This warranty is given only to the original purchaser at retail in either the United States or Canada and may not be transferred to any subsequent buyer. This warranty does not apply to purchasers of our products for use or resale in a business; a separate commercial warranty may protect those purchasers.

This warranty does not cover any Product failure caused by:

- (a) Abuse, damage or use of the Product in violation of the Product instructions.
- (b) Modification to any Product or part.
- (c) Failure to maintain the Product or part as described in accordance with the Product instructions.
- (d) Faulty installation or application.
- (e) Use of parts or accessories not compatible with this Product.
- (f) Floods, fires, winds, lightning, accidents, corrosive atmosphere, or other conditions beyond Midea’s control.
- (g) Interruption in electrical service or inadequate electrical service.
- (h) Replacement of fuses and replacement or resetting of circuit breakers.
- (i) Frozen or broken water pipes, water damage, moisture intrusion, mold or other biological growth.
- (j) The use, combination or linking of the Product to other products, processes or materials not provided by Midea.

### WARRANTY REMEDY

If any quality or performance issue covered by this warranty is discovered during the warranty period, we will, at our option, repair or replace any such Product. This warranty is limited to Product repair or replacement by an authorized Midea servicer or dealer and does not cover any shipping cost, labor cost, customs duties, inland logistics cost, or cost of service, including any diagnostics, removal, transportation, or reinstallation costs. If we ask, you must return the Product to us.

### WARRANTY DISCLAIMER; EXCLUSION OF DAMAGES

This is the only express warranty to consumers that we offer on our Products. **ANY IMPLIED WARRANTIES BY MIDEA, INCLUDING BUT NOT LIMITED TO WARRANTIES OF MERCHANTABILITY AND FITNESS FOR PARTICULAR PURPOSE, ARE LIMITED TO THE DURATION OF THIS EXPRESS WARRANTY.** Some states and provinces do not allow the exclusion of express warranties and/or limitations on how long an implied warranty lasts, so the above exclusion and/or limitation may not apply to you.

**THE REMEDY DESCRIBED ABOVE IS THE ONLY ONE THAT WE WILL PROVIDE, EITHER UNDER THIS WARRANTY OR UNDER ANY WARRANTY ARISING BY OPERATION OF LAW. WE WILL NOT BE RESPONSIBLE FOR ANY CONSEQUENTIAL OR INCIDENTAL DAMAGES ARISING FROM THE BREACH OF THIS WARRANTY OR ANY OTHER WARRANTY, WHETHER EXPRESS OR IMPLIED, NEGLIGENCE OR OTHER TORT, OR ON ANY STRICT LIABILITY THEORY, INCLUDING BUT NOT**

**LIMITED TO LOST PROFITS.** Some states do not allow the exclusion or limitation of incidental or consequential damages, so the above exclusion may not apply to you.

## WARRANTY CLAIMS PROCESS

For more information or to make a warranty claim, please visit:

<https://www.midea.com/us/support>

Or contact us at:

Telephone: 1-866-646-4332

Email: [customerserviceusa@midea.com](mailto:customerserviceusa@midea.com)

You must have Your bill of sale, delivery slip, or appropriate proof of purchase to submit a warranty claim. The date of delivery establishes the warranty period, should service be required.

## DISPUTE RESOLUTION

### **ARBITRATION CLAUSE. IMPORTANT. PLEASE REVIEW THIS ARBITRATION CLAUSE. IT AFFECTS YOUR LEGAL RIGHTS.**

- (a) *Parties*: This arbitration clause (this “Arbitration Clause”) affects your rights against Midea and any of its affiliates or employees or agents, successors, or assigns, all of whom together are referred to below as “we” or “us” for ease of reference.
- (b) **ARBITRATION REQUIREMENT: EXCEPT AS STATED BELOW, ANY DISPUTE BETWEEN YOU AND ANY OF US SHALL BE DECIDED BY NEUTRAL, BINDING ARBITRATION RATHER THAN IN COURT OR BY JURY TRIAL.** “Dispute” will be given the broadest possible meaning allowable by law. It includes any dispute, claim, or controversy arising from or relating to your purchase of this Product, any warranty upon the Product, or the Product’s condition. It also includes determination of the scope or applicability of this Arbitration Clause. The arbitration requirement applies to claims in contract and tort, pursuant to statute, or otherwise.
- (c) **CLASS-ARBITRATION WAIVER: ARBITRATION IS HANDLED ON AN INDIVIDUAL BASIS. IF A DISPUTE IS ARBITRATED, YOU AND WE EXPRESSLY WAIVE ANY RIGHT TO PARTICIPATE AS A CLASS REPRESENTATIVE OR CLASS MEMBER ON ANY CLASS CLAIM YOU MAY HAVE AGAINST US OR WE AGAINST YOU, OR AS A PRIVATE ATTORNEY GENERAL OR IN ANY OTHER REPRESENTATIVE CAPACITY, TO THE MAXIMUM EXTENT PERMITTED BY LAW. YOU AND WE ALSO WAIVE ANY RIGHT TO CLASS ARBITRATION OR ANY CONSOLIDATION OF INDIVIDUAL ARBITRATIONS.**
- (d) *Discovery and Other Rights*: Discovery and rights to appeal in arbitration are generally more limited than in a lawsuit. This applies to both you and us. Other rights that you or we would have in court may not be available in arbitration. Please read this Arbitration Clause and consult the rules of the arbitration organizations listed below for more information.
- (e) **SMALL CLAIMS COURT OPTION: YOU MAY CHOOSE TO LITIGATE ANY DISPUTE BETWEEN YOU AND ANY OF US IN SMALL CLAIMS COURT, RATHER THAN IN ARBITRATION, IF THE DISPUTE MEETS ALL REQUIREMENTS TO BE HEARD IN SMALL CLAIMS COURT.**
- (f) *Governing Law*: For residents of the United States, the procedures and effect of the arbitration will be governed by the Federal Arbitration Act (9 U.S.C. § 1 et seq.) rather than by state law concerning arbitration. For residents of Canada, the procedures and effect of the arbitration will be governed by the applicable arbitration law of the province in which you purchased your Product. The law governing your substantive warranty rights and other claims will be the law of the state or province in which you purchased your Product. Any court having jurisdiction may enter judgment on the arbitration award.

- (g) *Rules of the Arbitration*: If the amount in controversy is less than \$250,000, the arbitration will be decided by a single arbitrator. If the amount in controversy is greater than or equal to \$250,000, the arbitration will be decided by a panel of three arbitrators. The arbitrator(s) will be chosen pursuant to the rules of the administering arbitration organization. United States residents may choose JAMS (1920 Main Street, Ste. 300, Irvine, CA 92614, [www.jamsadr.com](http://www.jamsadr.com)), or, subject to our approval, any other arbitration organization. In addition, Canadian residents may choose the ADR Institute of Canada (234 Eglinton Ave. East, Suite 405, Toronto, Ontario, M4P 1K5, [www.amic.org](http://www.amic.org)). These organizations' rules can be obtained by contacting the organization or visiting its website. If the chosen arbitration organization's rules conflict with this Arbitration Clause, the provisions of this Arbitration Clause control. The award of the arbitrator(s) shall be final and binding on all parties.
- (h) *Location of the Arbitration Hearing*: Unless applicable law provides otherwise, the arbitration hearing for United States residents will be conducted in the federal judicial district in which you reside (in your hometown area) or, for Canadian residents, in the province in which you reside, and, if you choose, will be in-person.
- (i) *Costs of the Arbitration*: Each party is responsible for its own attorney, expert, and other costs and fees unless applicable law requires otherwise. Notwithstanding the preceding sentence, and unless applicable law requires otherwise, if you are a consumer under the JAMS rules or the rules of another agreed upon arbitration administrator, Midea will pay or reimburse you for all reasonable fees or costs to the extent required by law or the applicable arbitration administrator's rules. Whether or not required by law or such rules, if you prevail at arbitration on any claim against Midea, Midea will reimburse you for any reasonable fees paid to the arbitration administrator in connection with the arbitration proceedings. Under no circumstances will Midea seek from you payment or reimbursement of any reasonable fees that Midea incurs in connection with the arbitration. If you are required to advance any fees or costs to JAMS or other agreed upon arbitration administrator, but you ask Midea to do so in your stead, Midea will consider and respond to your request.
- (j) *Survival and Enforceability of this Arbitration Clause*: This Arbitration Clause shall survive the expiration or termination, or any transfer, of the warranty on your Product. If any part of this Arbitration Clause, except waivers of class-action rights, is found to be unenforceable for any reason, the remainder of this clause and the warranty shall remain enforceable. If, in a case in which class-action allegations have been made, the waiver of class-action rights under this warranty is found to be unenforceable with respect to any part of the dispute, the parts of the dispute as to which the waiver of class-action rights have been found unenforceable will be severed and will proceed in court without reference or application of this Arbitration Clause. Any remaining parts will proceed in arbitration.

## **QUEBEC RESIDENTS**

The arbitration provisions of this warranty shall not apply to residents of Quebec.



*make yourself at home*



[www.midea.com](http://www.midea.com)

© Midea 2022 all rights reserved